



INSTALLATION INSTRUCTIONS

Thank you for purchasing a LOMAX™ Folding Hard or Professional Series Cover. Agri-Cover, Inc. proudly manufactured this cover using superior quality materials and workmanship. With proper care, your cover will provide years of service and enjoyment.

NOTICE TO INSTALLER: Even if familiar with cover, read instructions prior to installation as improvements may be made without notice. Always handle cover and components with care. If you have questions or problems, have serial number ready and call customer service. When done, these instructions must be given to the consumer.

NOTICE TO CONSUMER: Before using cover, read operating, maintenance and safety sections. Save these instructions for future reference.

FOR YOUR RECORDS

DATE PURCHASED: _____

WHERE PURCHASED: _____

SERIAL NUMBER: _____

(Located on decal under rear panel)



AGRI-COVER, INC.

Questions? 844-566-2987

agricover.com

PREPARATION

This document is typically used with trucks that have 6' or longer boxes. Unpack cover components and clean truck box if dirty. For additional installation assistance, go to lomaxcovers.com for install video.

COMPONENTS

- (8) Clamps
- (2) Driver side rails
- (2) Passenger side rails
- (2) Safety straps
- Pre-folded cover assembly

TOOLS NEEDED

- 1/2" Wrench
- 7/16" Wrench
- Torque wrench with 1/2" socket
- Protective eyewear
- Spring clamp (optional)

NOTE: With an under the rail drop-in bed liner, installation is possible with minimal trimming/cutting of bed liner at front corner of box and back by tailgate to allow side rail to install properly. Considerable trimming/cutting is required with an over the rail drop-in bed liner.

NOTE: For additional protection against the elements, locate and seal miscellaneous factory holes, crevices, stake pockets, etc. that may be in box (sealant not included).

NOTE: Tonneau cover and side rail appearance may vary. Typically a vehicle with a 6' or longer box is provided with two multi-piece side rails.

▲ CAUTION: Over torquing hardware may damage components.

PARTS DIAGRAM

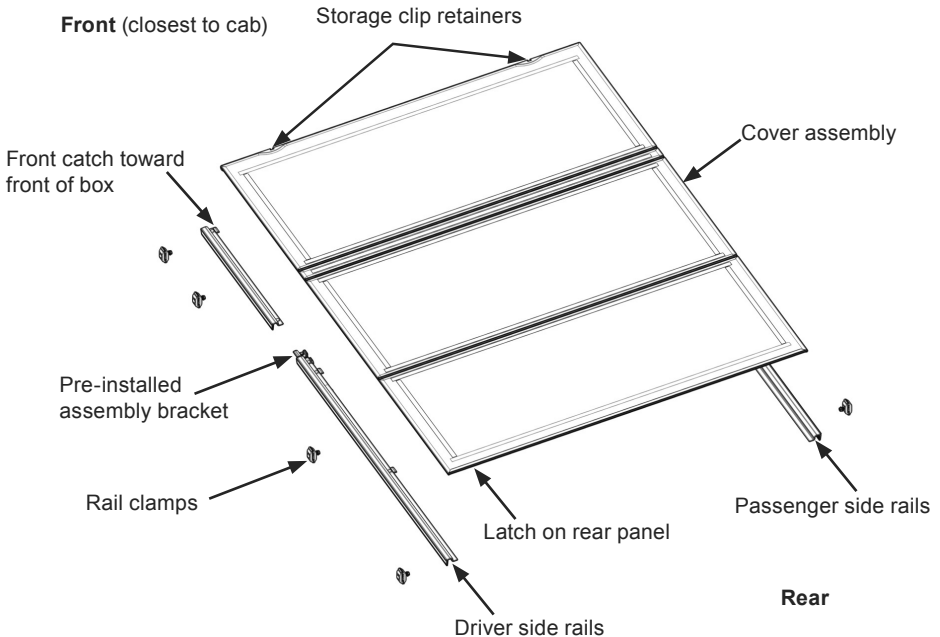

1: INSTALLING SIDE RAILS

NOTE: Some installs require special instructions. If required, follow special instructions for side rail attachment along with these standard instructions.

- A. Locate two side rail sections with matching profiles displayed in image below.
- B. On side rail section without pre-installed bracket, remove 1/4"-20 x 3/4" carriage bolt and 1/4"-20 nylock hex nut from rail end.
- C. Slide end of short rail (front) with mounting hole onto assembly bracket pre-installed on longer rail (rear).

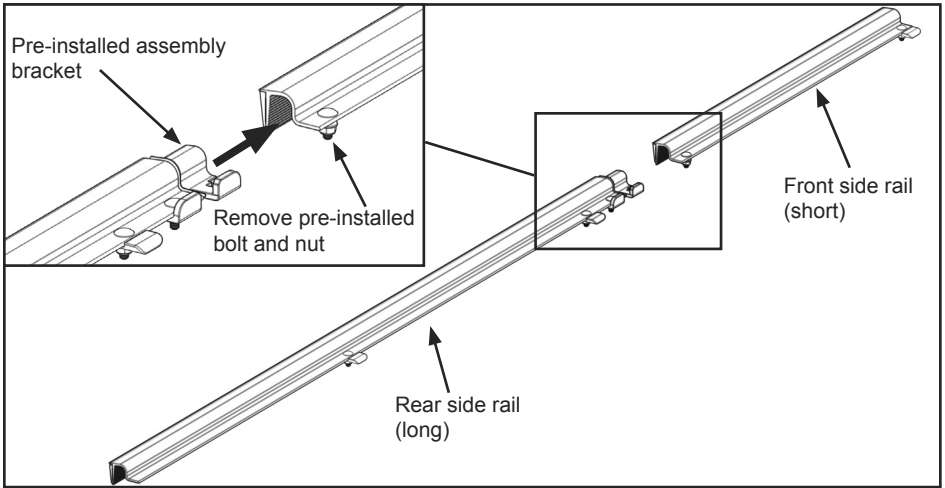

D. Attach short side rail (front) to assembly bracket with previously removed 1/4"-20 x 3/4" carriage bolt and 1/4"-20 nylock hex nut. Align side rails then tighten with 7/16" wrench.

NOTE: Side rails should have little to no gap at assembly bracket.

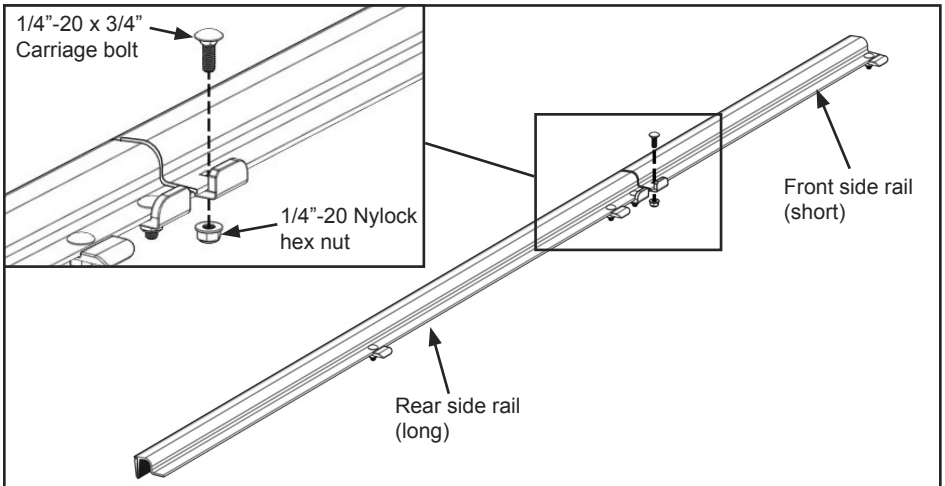

1: INSTALLING SIDE RAILS (Continued)

E. Position side rail with weather strip against inside lip of box, front catch toward front of box and side rail guide set on top of box. Push side rail forward until it touches front of box.

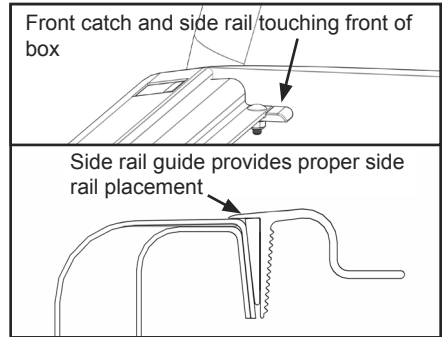

F. At front hold side rail with assistance of another person or a spring clamp.

G. Install first clamp as close to front of box as possible with clamp orientation that provides best grip, turn nut finger tight, then use 1/2" wrench to tighten.

IMPORTANT: To keep side rail secured on truck, ensure clamp teeth engage grooves on side rail.

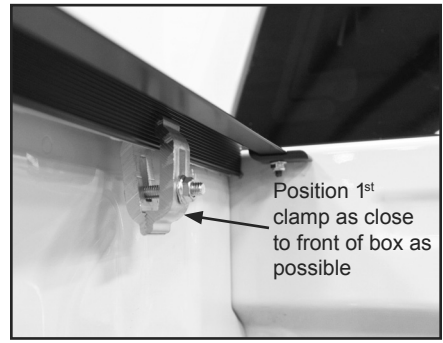

NOTE: Images below illustrate clamping options. **Option A** depicts standard clamping orientation lower on the side rail. **Option B** depicts alternate clamping orientation with half of clamp assembly rotated 180° to provide better grip at top of side rail.

H. Verify side rail is level. If side rail is not level, perform one of the following:

If side rail tilts up: loosen and lower clamp, engage teeth and then retighten clamp.

If side rail tilts down: loosen and raise clamp, engage teeth and then retighten clamp.

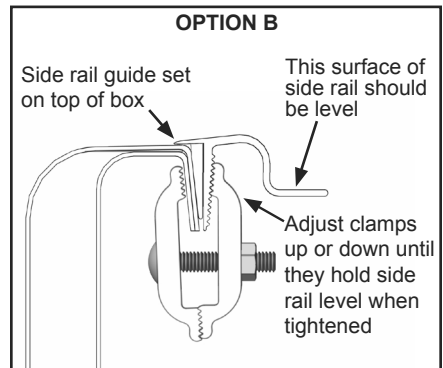
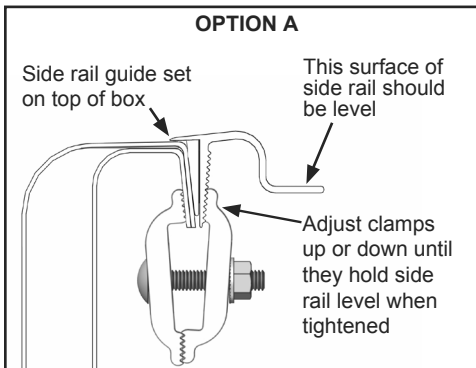

1: INSTALLING SIDE RAILS (Continued)

I. With side rail guide set on top of box, install second clamp at side rail splice (where two side rail sections meet). Repeat clamping procedure.

NOTE: The second clamp covers the side rail splice and engages grooves on both rail sections. If clamp cannot be installed on side rail splice, install second clamp as close as possible to side rail splice favoring rail section closest to cab.

J. With side rail guide set on top of box, install third clamp 2/3rds from front of box. Repeat clamping procedure.

K. At rear of box, place rear clamp as close to tailgate as possible. Repeat clamping procedure.

IMPORTANT: To keep side rail secured on truck, ensure clamp teeth engage grooves on side rail.

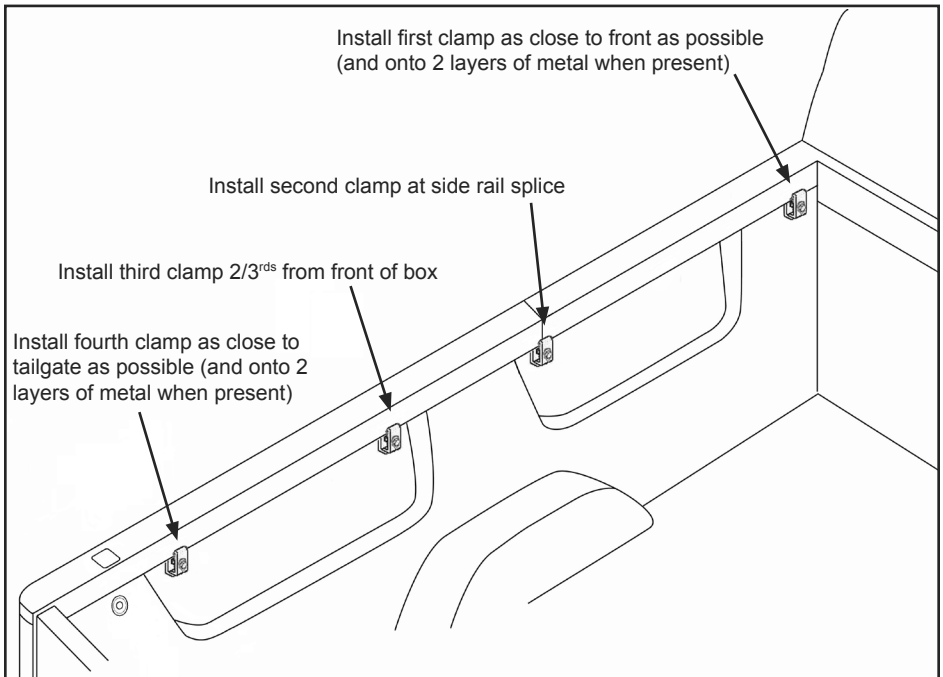

NOTE: For trucks with electric tailgates, typically side rail must be installed slightly higher to eliminate interference.

L. Repeat Step 1 to install side rail on opposite side.

M. Torque all clamps to 20 ft-lbs or value specified in special instructions (if supplied).

2: INSTALLING COVER

A. At front of box, lift folded cover above side rails and place leading edge of front panel on front rails. Hold cover rear edge 1" above side rails and slide cover hooks underneath front rail catch on each side.

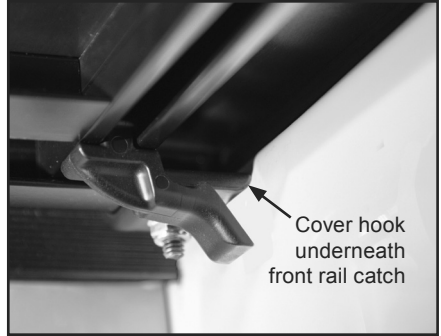

B. With cover hooks engaged underneath front catches, lower cover to engage latches in retainment brackets on each side.

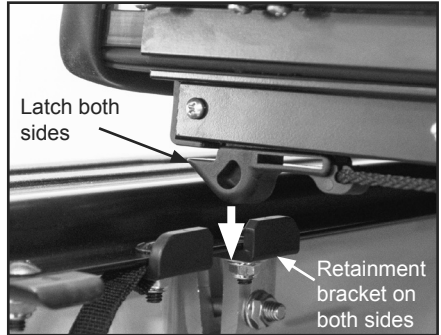

C. Attach safety straps to safety strap brackets on each side.

IMPORTANT: Always ensure safety straps are attached to cover and side rails.



2: INSTALLING COVER (Continued)

D. Unhook storage clips at front of cover and unfold middle panel toward tailgate.



E. Unfold rear panel toward tailgate.

IMPORTANT: Always ensure hooks and latches fully engaged catches and side rails.

NOTE: After installation, cover should remain on truck box in closed position for at least 48 hours. During this time period the cover typically conforms to truck box.

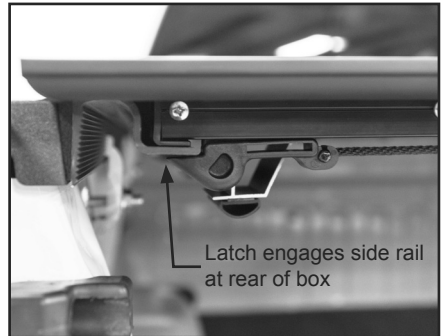

TROUBLESHOOTING

PROBLEM

SOLUTION

Top of tailgate hits cover when attempting to close

Verify top of side rail guide is set on top of box. Side rails are set too low at rear of cover, raise rails at rear of box until cover no longer interferes with tailgate operation (see Step 1).

Gap between cover and truck box or tailgate

Verify top of side rail guide is set on top of box. Side rails are set too high (see Step 1).

Seal on edge of cover is not sealing tight with top of side rail and truck box

Verify top of side rail guide is set on top of box. Side rails are set too high (see Step 1).

Latch doesn't engage

Check side rails for height and level (see Step 1). Inspect latches for jammed or broken parts.

Cover is not parallel with side rails

With cover installed on box, loosen hardware on both retainment brackets with 7/16" wrench (DO NOT REMOVE HARDWARE). Unfold cover to closed position and square up with box. Carefully fold cover back to open position and retighten retainment bracket hardware.

OPENING TRI-FOLD COVER

IMPORTANT: Remove debris or snow from hinges before opening cover.

IMPORTANT: To avoid damage or misalignment of hinge points, open cover in a smooth, fluid manner.

A. Open tailgate, pull release latch.



B. Fold panels toward the cab.



C. Fasten storage clips on both sides to store the cover.



CLOSING TRI-FOLD COVER

IMPORTANT: Remove debris or snow from hinges before opening cover.

IMPORTANT: To avoid damage or misalignment of hinge points, close cover in a smooth, fluid manner.

A. Open tailgate, unfasten storage clips on both sides.



B. Unfold panels toward tailgate.

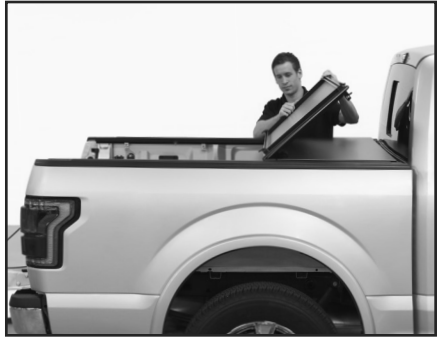

C. Always ensure hooks and latches fully engage catches and side rails. Close tailgate.



REMOVING AND REINSTALLING COVER

REMOVE COVER

- A. With cover open and storage clips secured, detach safety straps from safety brackets.
- B. Pull tab on front panel and lift rear edge of cover 1" above side rails (Figure 1).
- C. Slide cover back to disengage hooks, then lift to remove (Figure 2).
- D. Attach safety strap carabiner to retaining loop.

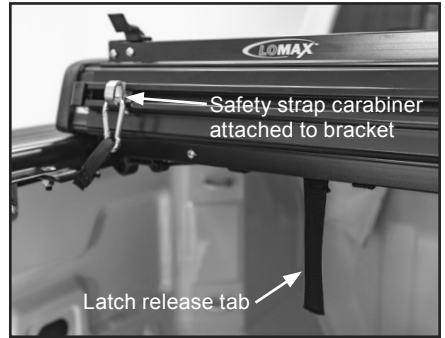

REINSTALL COVER

- A. At front of box, set front edge of cover on side rails and hold rear edge 1" above rails (Figure 1).
- B. Slide cover forward to engage hooks underneath catches (Figure 2).
- C. Lower cover to engage latches in retainment brackets.
- D. Secure safety straps to safety brackets

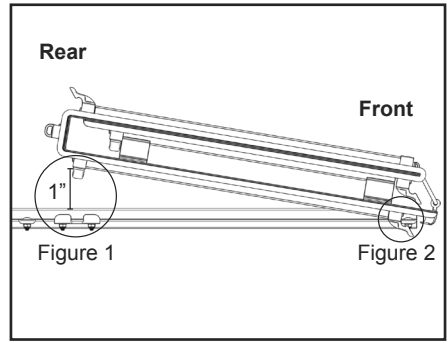

▲ WARNING: ALWAYS PROPERLY SECURE COVER

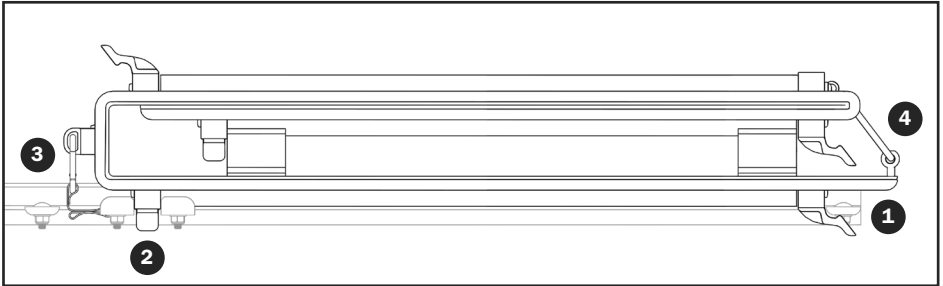

Failure to execute these steps may result in severe damage and will void your warranty.

1. Cover hooks engaged underneath rail catches.
2. Latches engaged in retainment brackets.
3. Safety straps attached to safety brackets.
4. Fasten storage clips if open.

SAFETY INFORMATION

- Always ensure hooks and latches fully engage catches and side rails.
- Ensure safety straps are attached to safety brackets when cover is installed on vehicle.
- Do not tow vehicle backward with cover on your truck.
- Do not cover cargo that is higher than the cover.
- Do not place object(s) on or against the cover or its framework at any time.
- Always secure cargo to ensure it does not damage cover or framework.
- Remove debris or snow from top of cover and hinges before opening or closing cover.
- Do not use the cover's framework to tie down cargo.
- Never stand, sit or ride on the cover or allow others to do so.
- The cover does not eliminate moisture and dust from entering the truck box. Special wrappings or packaging of the cargo may be necessary.
- Due to poor ventilation, if you allow a pet/animal in the box, leave cover open. Do not allow people or animals to occupy box with the cover closed.
- Use caution when operating cover in windy conditions.
- Keep cover completely closed or open and secured with storage clips. Do not attempt to drive with the rear panel in the partially open position.
- Use caution when cleaning cover and components with a pressure washer. Using a pressure washer too close to the cover may damage paint, hinge or seal.
- Keep cover closed when going through automatic car washes.
- Keep hands and fingers away from all pinch points.
- Never use latch cord to lift or fold cover.

TIPS FOR A LONGER LASTING COVER

- Keep cover closed when not in use.
- Avoid storing cover in its folded position for long periods of time.
- Ensure cover is properly latched while traveling and before entering automatic drive-through car washes.
- When cleaning, use mild liquid soap and water. Periodically treat cover and hinges with our COVER CARE® Cleaner and UV protectant. Never clean with petroleum or citrus based products. Petroleum based products may dry out and damage cover seal.

INSPECTION AND MAINTENANCE

The operator can perform most of inspection and maintenance. It may be necessary to review the installation and operating instructions.

- Periodically check and retighten safety strap hardware. If safety straps or brackets are damaged, replace with new hardware.
- Periodically check and retighten clamps as needed.
- Periodically check synthetic cords to ensure latches fully engage side rails.
- Periodically inspect cover assembly and the condition of all parts. Check for loose bolts and parts, tighten if needed. Test the operation to ensure parts are functioning properly and cover is in top operational condition.
- If latch has been damaged, replace with new one.

NOTE: Inspection and maintenance should also be performed anytime a malfunction is observed or suspected. If you need assistance inspecting or servicing your cover, or if you want to order a replacement part, call the customer service number on the back page. Always use original equipment replacement parts for your cover.

MANUFACTURER'S LIMITED WARRANTY

Agri-Cover, Inc. extends the following three (3) year Limited Warranty for the LOMAX™ Hard Folding Hard Cover or LOMAX™ Professional Series:

Agri-Cover, Inc. warrants a period of three (3) years from the date of manufacture that its LOMAX™ Folding Hard Cover or LOMAX™ Professional Series is free from defects in workmanship under normal use for the truck model it was intended for. This Limited Warranty does not cover any damage due to accident, abuse, misuse, alteration, neglect, improper installation, or ordinary wear and tear.

Agri-Cover, Inc.'s sole obligation under this Limited Warranty is limited to the repair or replacement at its option, of defective parts only. No labor or service allowance is given or implied. IN NO EVENT SHALL AGRI-COVER, INC. BE LIABLE FOR INCIDENTAL, CONSEQUENTIAL, OR SPECIAL DAMAGES. AGRI-COVER, INC. EXPRESSLY DISCLAIMS ANY AND ALL IMPLIED WARRANTIES OF MERCHANTABILITY, AND THERE ARE NO WARRANTIES WHICH EXTEND BEYOND THE LIMITED WARRANTY DESCRIPTION CONTAINED HEREIN.

For warranty, have serial number ready and fill out the warranty claim form at agricover.com/warrantyclaim or call Customer Service Department at 844-566-2987 to determine if only a replacement part is needed or if the cover needs to be returned for inspection and repair. Goods to be returned must have a pre-authorized RA # (Return Authorization Number) - obtained by calling the number above. Mark the number on the package and ship it freight prepaid to address below. Agri-Cover, Inc. will pay freight to return goods to sender.

This Limited Warranty gives you specific legal rights and you may have other rights, which vary, from state to state.

For replacement parts shop at lomaxparts.com or call Customer Service at 844-566-2987.



Agri-Cover, Inc.
Customer Service Dept
3000 Hwy 281 SE
Jamestown, ND 58401
Phone: 844-566-2987

Hours: 8:00 am - 5:00 pm CST Monday through Friday, except Holidays