

iArmor[®]

iArmor[®] by APS

PART#: IA-S022

BEFORE INSTALLATION

REMOVE CONTENTS FROM BOX. VERIFY ALL PARTS ARE PRESENT. READ INSTRUCTIONS CAREFULLY BEFORE STARTING INSTALLATION. ASSISTANCE IS RECOMMENDED. THANK YOU FOR CHOOSING OUR PRODUCT!

*ROCKER PANEL MOUNT

*NO DRILLING /TRIMMING REQUIRED

Fastener Size	Tightening Torque (ft-lbs)	Required
6mm	6-7	X
8mm	16-18	√
10mm	31-32	X
12mm	56-58	X
14mm	92-94	X

Item	QTY	Description	Item	QTY	Description
1#	3	Driver Front & Center & Passenger Rear Mounting Brackets	7#	12	M8X1.25 Hex Flange Nuts
2#	3	Passenger Front & Center & Driver Rear Mounting Brackets	8#	12	M8X1.25-20mm Hex Bolts
3#	6	Bar Brackets	9#	24	M8 Large Flat Washers
4#	6	U Brackets	10#	18	M8 Lock Washers
5#	12	Spacers	11#	18	M8X1.25 Hex Nuts
6#	12	M8X1.25-20mm Hex Flange Bolts	12#	6	M8X1.25-55mm Carriage Bolts

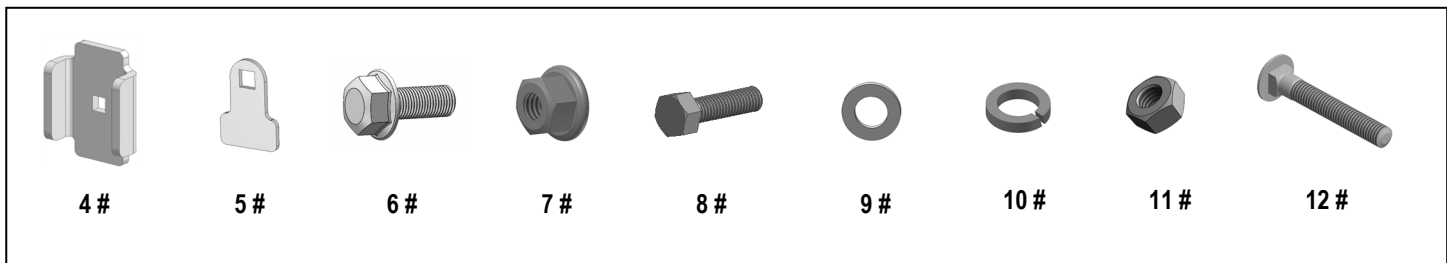

iArmor[®]

Driver

Front

Passenger

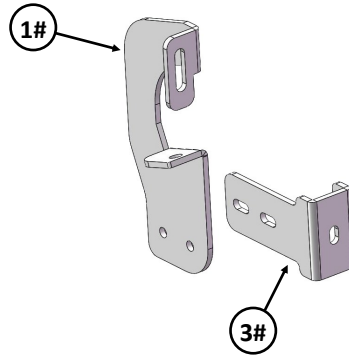
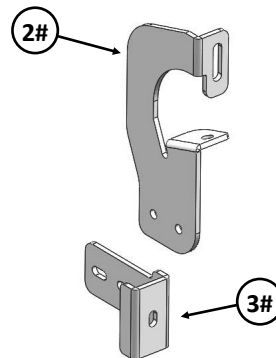
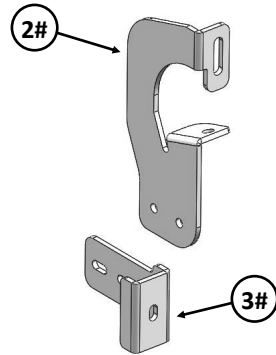
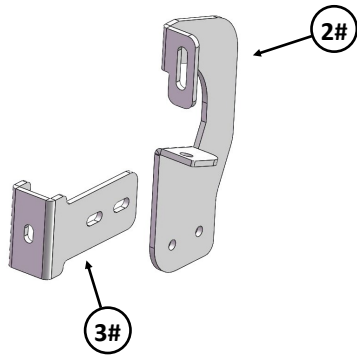
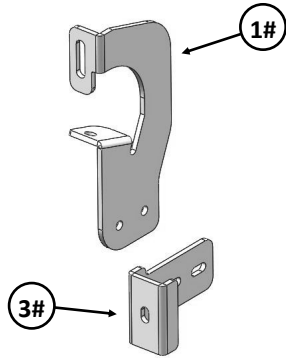
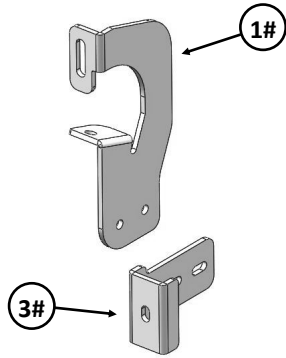
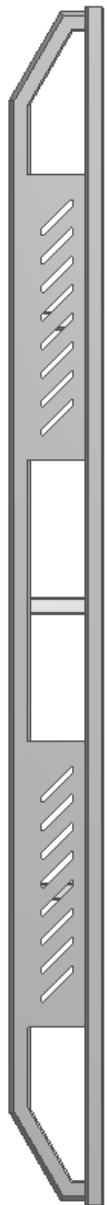

iArmor®

The instruction here is for your reference only. We strongly recommend the professional installer for best result. We are not responsible for any damage caused by the installation.

STEP 1

Start the installation from driver side. Assemble the Driver Front Mounting Bracket and the Bar Bracket as shown, (Fig 1). Don't fully tighten hardware at this time. Repeat to assemble other (2) brackets.

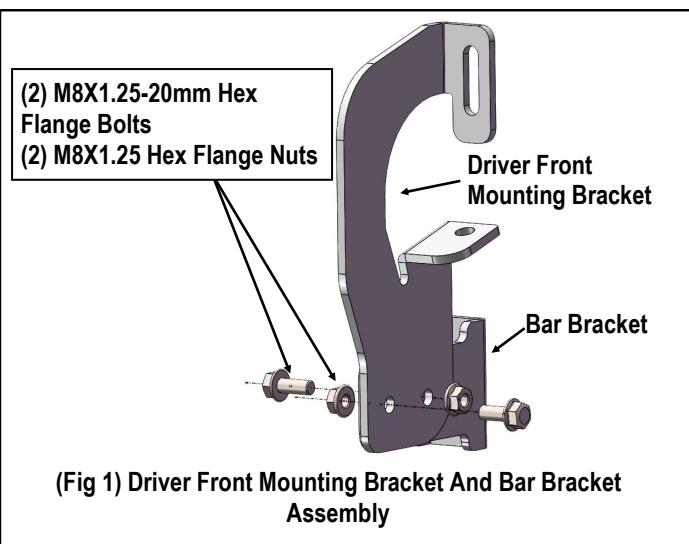

STEP 2

Install the Driver Side Brackets as shown (Fig 2). Don't fully tighten at this time.

STEP 3

Once all (3) driver side mounting brackets are installed, select and attach the Driver Side Step Bar onto the Mounting Brackets with (3) U Brackets, (6) Spacers, (3) M8X1.25-55mm Carriage Bolts, (3) M8 Large Flat Washers, (3) M8 Lock Washers and (3) M8X1.25 Hex Nuts (Fig 3). Do not fully tighten hardware at this time.

STEP 4

Properly level and adjust the Step Bar and fully tighten all hardware.

STEP 5

Move to the passenger side of the vehicle. Repeat Steps 1-4 to install the passenger side step bar.
Installation completed.

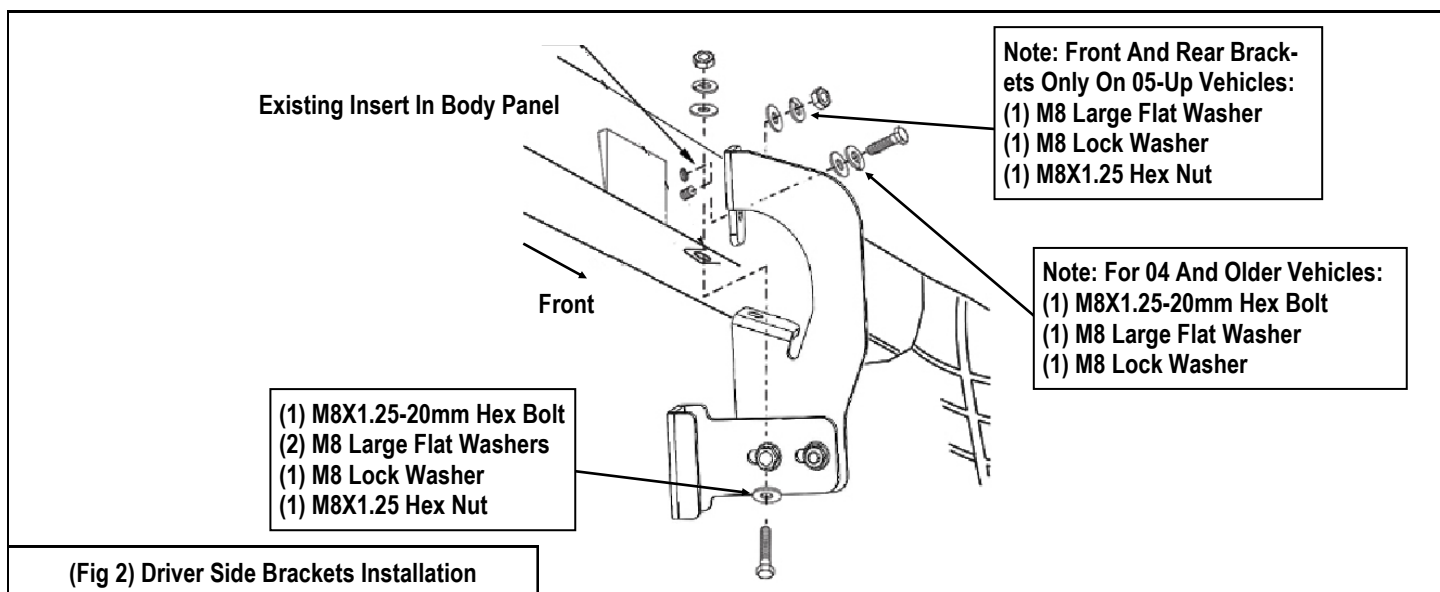

iArmor[®]

Attention

Do periodic inspections to the installation to make sure that all hardware is secure and tight. In order to protect your bars/boards, please use only mild soap/non-abrasive products for cleaning.

NOTE: Torque all M8 X1.25-55mm Carriage Bolts to 16~18 lb-ft. Don't over tighten, or the aluminum square bars will be damaged by the brackets

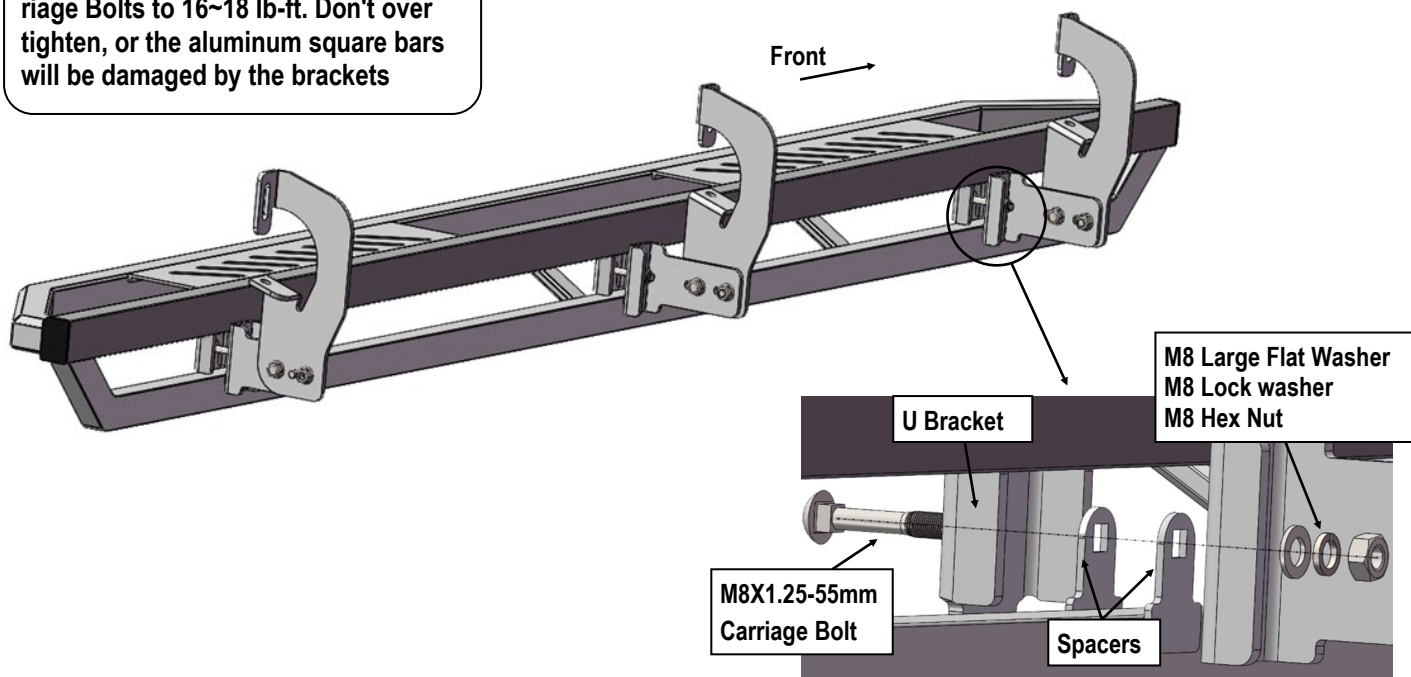

(Fig 3) Driver Side Step Bar Installed