

iArmor[®]

iArmor[®] by APS

PART#: IA-S108

BEFORE INSTALLATION

REMOVE CONTENTS FROM BOX. VERIFY ALL PARTS ARE PRESENT. READ INSTRUCTIONS CAREFULLY BEFORE STARTING INSTALLATION. ASSISTANCE IS RECOMMENDED. THANK YOU FOR CHOOSING OUR PRODUCT!

*ROCKER PANEL MOUNT

*NO DRILLING /TRIMMING REQUIRED

Fastener Size	Tightening Torque (ft-lbs)	Required
6mm	6-7	X
8mm	16-18	√
10mm	31-32	X
12mm	56-58	X
14mm	92-94	X

Item	QTY	Description	Item	QTY	Description
1#	2	Driver Front & Passenger Rear Mounting Brackets	8#	8	M8X1.25-25mm Hex Bolts
2#	2	Driver Front & Passenger Rear Support Brackets	9#	40	M8 Large Flat Washers
3#	2	Passenger Front & Driver Rear Mounting Brackets	10#	24	M8 Lock Washers
4#	2	Passenger Front & Driver Rear Support Brackets	11#	20	M8X1.25 Hex Nuts
5#	4	U Brackets	12#	4	M8 Clip Nuts
6#	8	Spacers	13#	4	M8X1.25-55mm Carriage Bolts
7#	12	M8X1.25-30mm Hex Bolts			

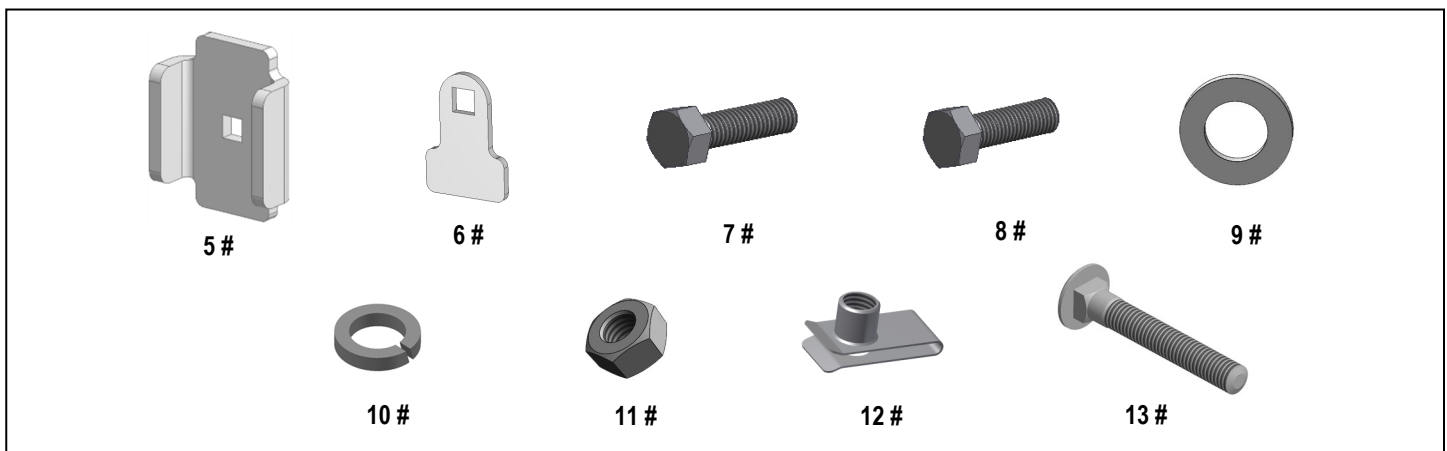

Customer Support: info@iarmorauto.com

iArmor®

Driver

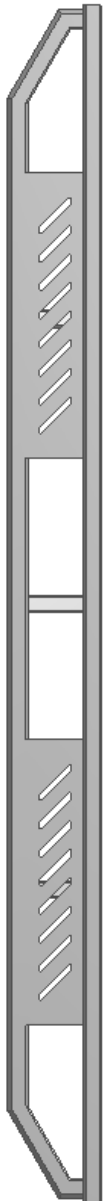

Front



Passenger

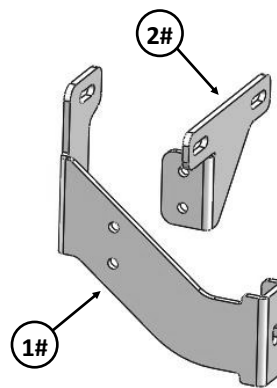
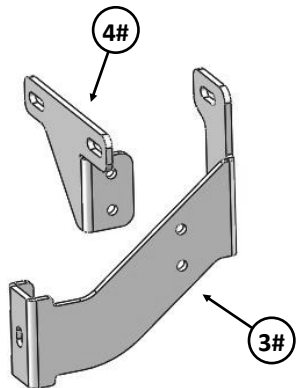
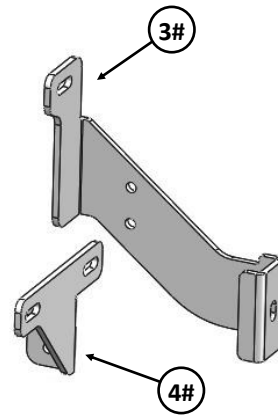
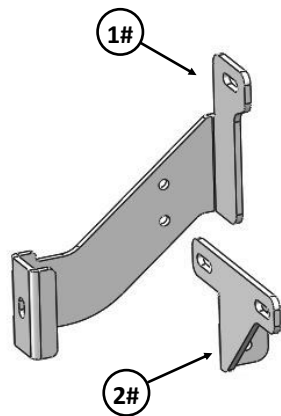

iArmor®

The instruction here is for your reference only. We strongly recommend the professional installer for best result. We are not responsible for any damage caused by the installation.

STEP 1

Start on the driver side of the vehicle. Assemble Driver Front Mounting Bracket and Driver Front Support Bracket with (2) M8X1.25-25mm Hex Bolts, (4) M8 Large Flat Washers, (2) M8 Lock Washers and (2) M8X1.25 Hex Nuts, (Fig 1). Do not fully tighten hardware at this time.

Repeat for Driver Rear Mounting Bracket and Driver Rear Support Bracket assembly, (Fig 2).

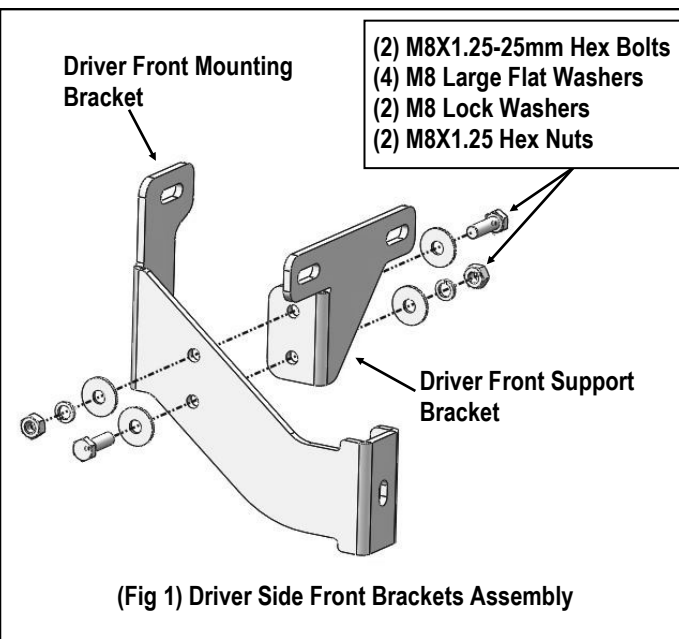

STEP 2

Attach driver side brackets to the rocker panel and pinch weld as shown, (Figs 3-4). Do not fully tighten hardware at this time.

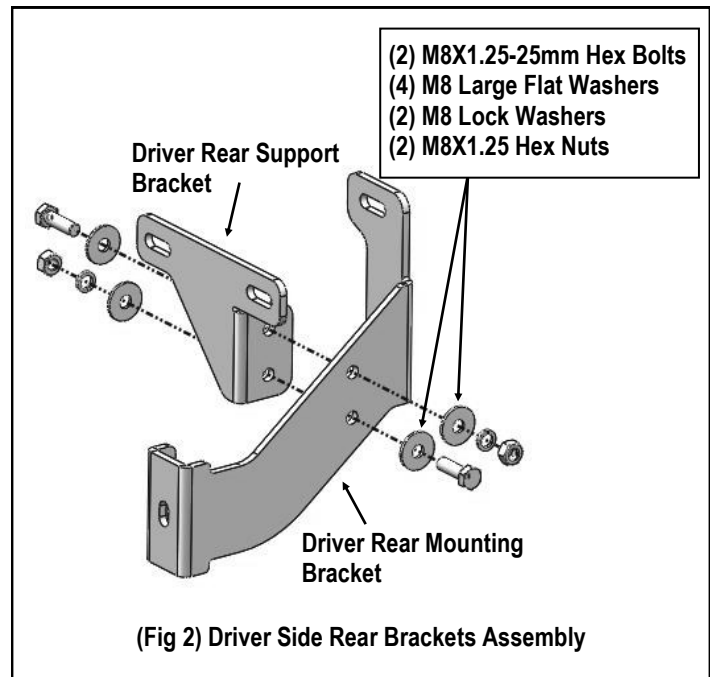

STEP 3

For jeep Commanders only: To attach the passenger side front bracket, remove the (4) bolts that secure the rear air and heat line shroud.

Remove the shroud to gain access to top mounting location on the bracket. After bracket is installed and fasteners are tightened, reattach shroud with the four existing bolts previously removed, (Fig 5).

STEP 4

Once all (2) driver side mounting brackets are installed, select and attach the assembled Driver Side Step Bar onto the Mounting Brackets with (2) U Brackets, (4) Spacers, (2) M8X1.25-55mm Carriage Bolts, (2) M8 Large Flat Washers, (2) M8 Lock Washers and (2) M8X1.25 Hex Nuts (Fig 6). Do not fully tighten hardware at this time.

STEP 5

Properly level and adjust the Step Bar and fully tighten all hardware.

iArmor®

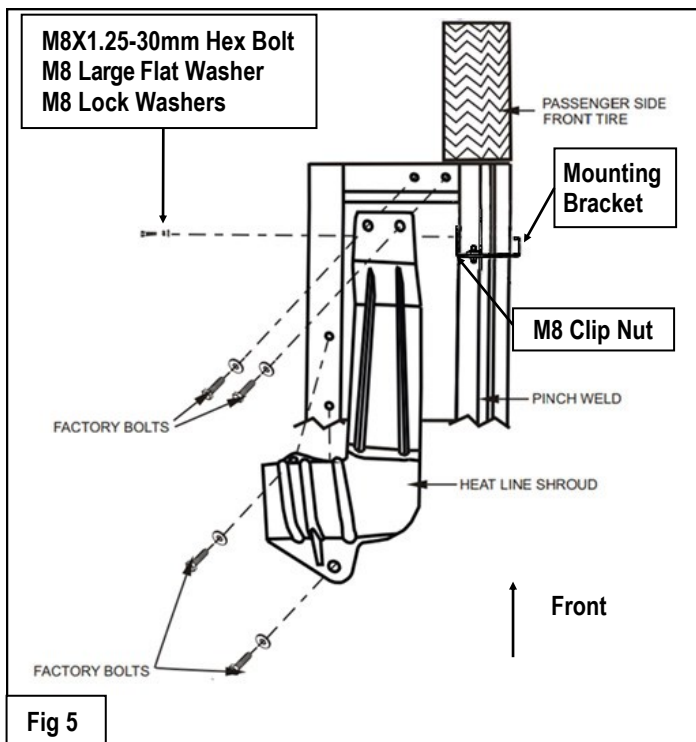
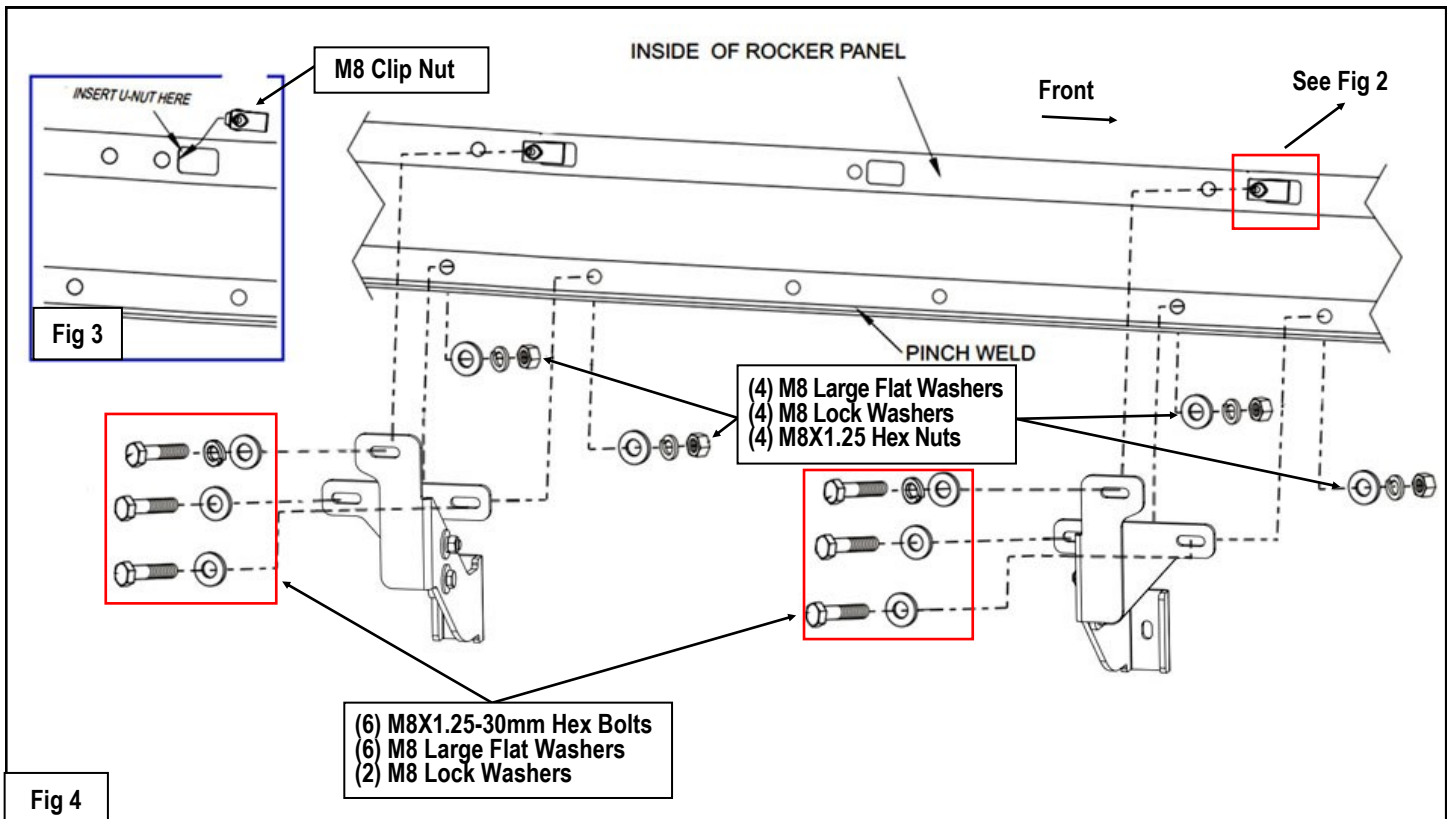

STEP 6

Move to the passenger side of the vehicle. Repeat **Steps 1-5** to install the passenger side step bar.
Installation completed.

Attention

Do periodic inspections to the installation to make sure that all hardware is secure and tight.

In order to protect your bars/boards, please use only mild soap/non-abrasive products for cleaning.

iArmor[®]

NOTE: Torque all M8 X1.25-55mm Carriage Bolts to 16~18 lb-ft. Don't over tighten, or the aluminum square bars will be damaged by the brackets

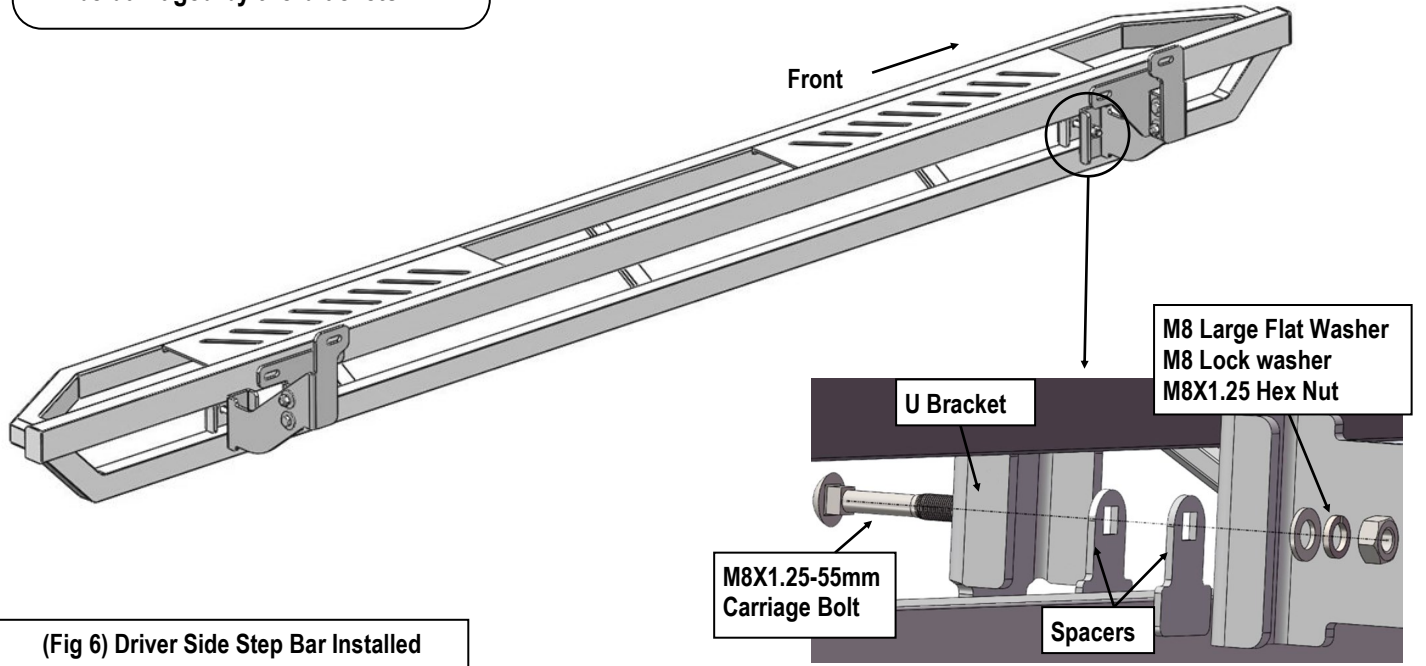

(Fig 6) Driver Side Step Bar Installed