

# iArmor<sup>®</sup>

## iArmor<sup>®</sup> by APS

PART#: IA-S277

### BEFORE INSTALLATION

REMOVE CONTENTS FROM BOX. VERIFY ALL PARTS ARE PRESENT. READ INSTRUCTIONS CAREFULLY BEFORE STARTING INSTALLATION. ASSISTANCE IS RECOMMENDED. THANK YOU FOR CHOOSING OUR PRODUCT!

**\*ROCKER PANEL MOUNT**

**\*NO DRILLING / TRIMMING REQUIRED**

### Torque Value

Fastener Size	Tightening Torque (ft-lbs)	Required
6mm	6-7	√
8mm	16-18	√
10mm	31-32	√
12mm	56-58	X
14mm	92-94	X

### PART LIST

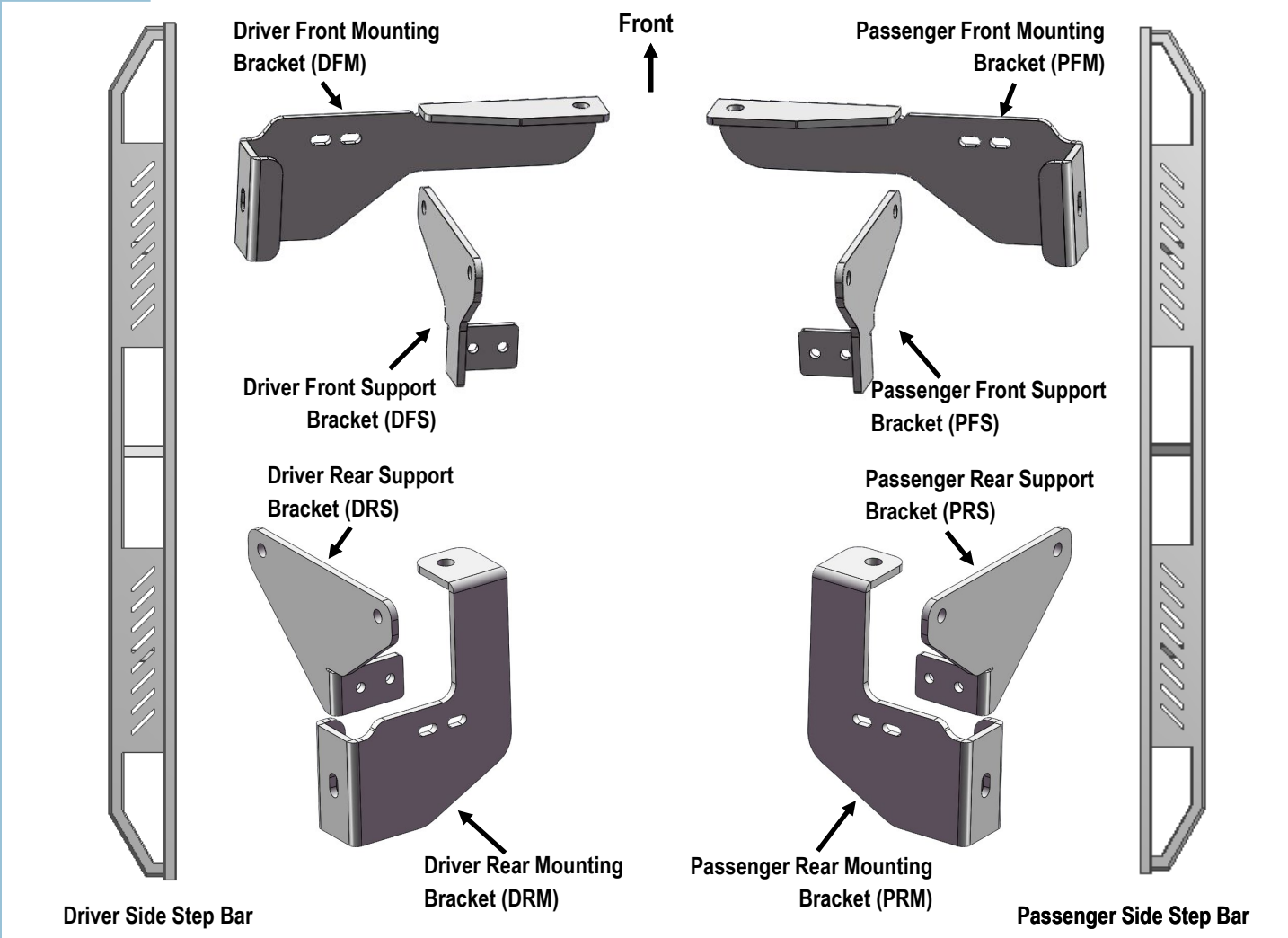

Customer Support: [info@iarmorauto.com](mailto:info@iarmorauto.com)

# iArmor<sup>®</sup>



The instruction here is for your reference only. We strongly recommend the professional installer for best result. We are not responsible for any damage caused by the installation.

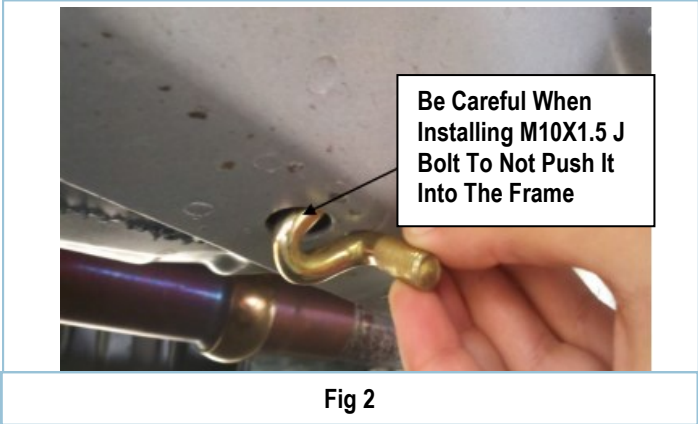

## STEP 1

Starting from the front driver side of the vehicle Install M10X1.5 J-Bolt in the large hole in the frame, (Fig 1, 2).

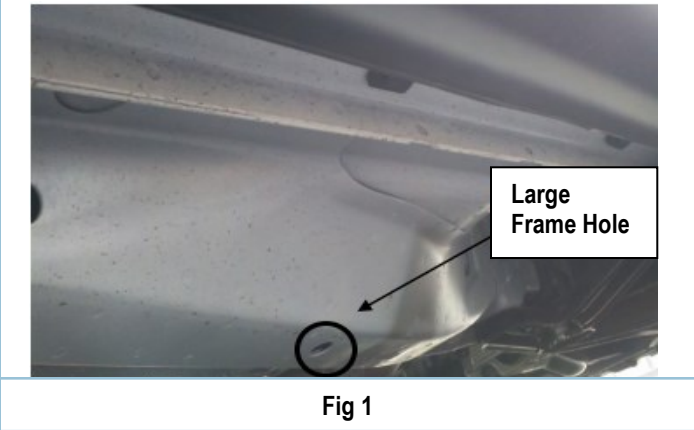

## STEP 2

Some models require to enlarge the holes on pinch weld (Fig 3).

# iArmor®

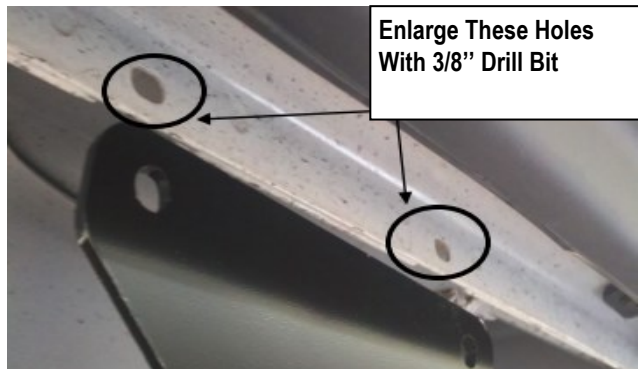
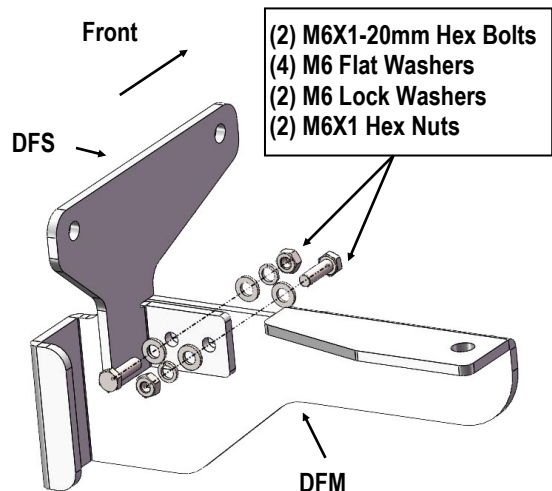

Fig 3

## STEP 3

Assemble Driver Front Mounting Bracket (DFM) and Driver Front Support Bracket (DFS) as shown, (Fig 4). Do not tighten fully at this time.



(Fig 4) Driver Front Mounting Bracket (DFM) And Driver Front Support Bracket (DFS) Assembly Pictured

## STEP 4

Install the Assembled Driver Side Front Brackets to the M10X1.5 J-Bolt using (1) M10 Large Flat Washer, (1) M10 Lock Washer, (1) M10X1.5 Hex Nut. Secure the front bar bracket to the outside of the pinch weld using (2) M8X1.25-20mm Hex Bolts, (4) M8 Flat Washers, (2) M8 Lock Washers and (2) M8X1.25 Hex Nuts, (Fig 5). Do not tighten fully at this time.

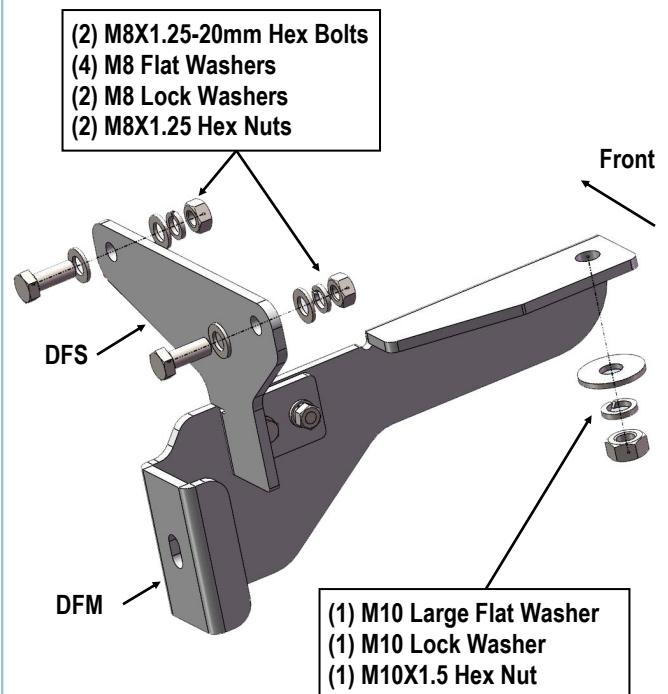

(Fig 5) The Assembled Driver Front Mounting Bracket Installation

## STEP 5

Assemble Driver Rear Mounting Bracket (DRM) and Driver Rear Support Bracket (DRS) as shown (Fig 6).

## STEP 6

Remove the M10 fuel tank strap bolt and install the **Assembled Driver Side Rear Mounting Bracket** using (1) M10X1.5-35mm Hex Bolt, (2) M10 Large Flat Washers, (1) M10 Lock Washer and (1) M10X1.5 Hex Nut. Secure the Driver Rear Bar Bracket (**DRS**) to the outside of the pinch weld using (2) M8X1.25-20mm Hex Bolts, (4) M8 Flat Washers, (2) M8 Lock Washers and (2) M8X1.25 Hex Nuts. Do not tighten fully at this time, (Fig 6).

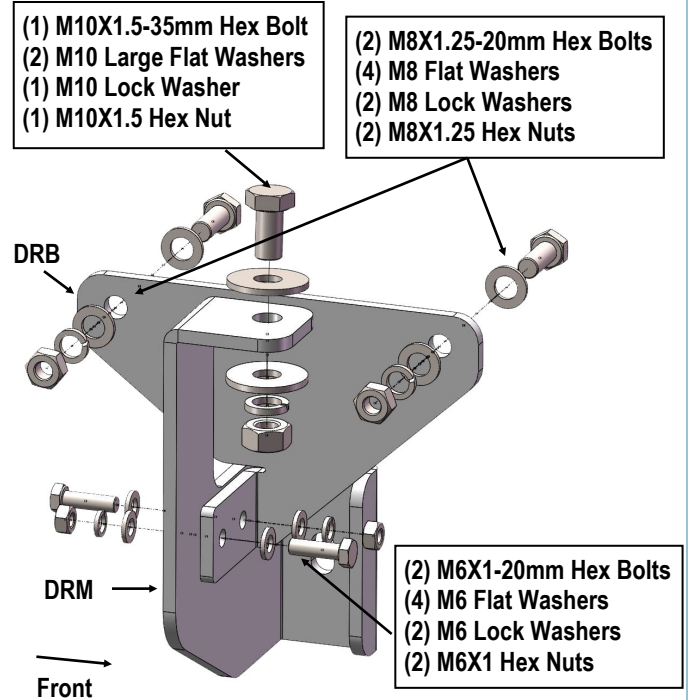

(Fig 6) Driver Side Rear Bracket Installation

## STEP 7

Once all (2) driver side mounting brackets are installed, select and attach the Driver Side Step Bar onto the Mounting Brackets with (2) U Brackets, (4) Spacers, (2) M8X1.25-55mm Carriage Bolts, (2) M8 Large Flat Washers, (2) M8 Lock Washers and (2) M8X1.25 Hex Nuts (Fig 7). Do not fully tighten hardware at this time.

**NOTE:** Torque all M8 X1.25-55mm Carriage Bolts to 16~18 lb-ft. Don't over tighten, or the aluminum square bars will be damaged by the brackets

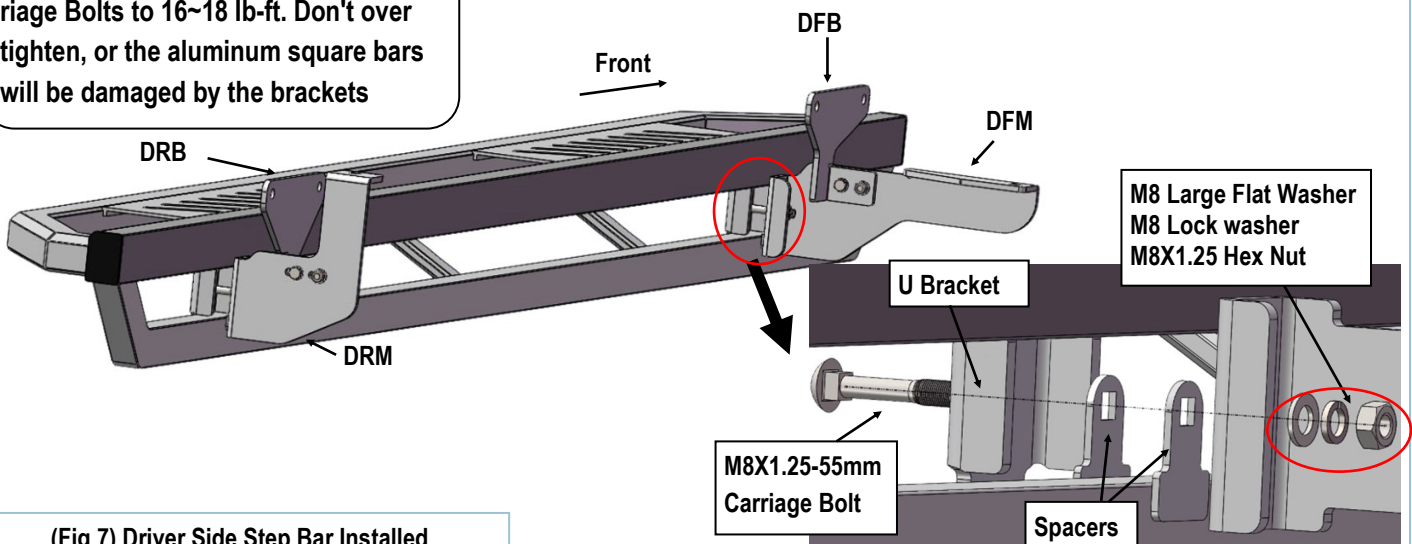

(Fig 7) Driver Side Step Bar Installed

# iArmor<sup>®</sup>

## STEP 8

Properly level and adjust the Step Bar and fully tighten all hardware.

## STEP 9

Move to the passenger side of the vehicle. Repeat **Steps 1-8** to install passenger side step bar.

Installation completed.

### Attention

**Do periodic inspections to the installation to make sure that all hardware is secure and tight.**

**In order to protect your bars/boards, please use only mild soap/non-abrasive products for cleaning.**