

# iBoard®

## iBoard® by APS

PART#: IB-030

READ INSTRUCTIONS CAREFULLY BEFORE STARTING INSTALLATION. REMOVE CONTENTS FROM BOX AND VERIFY ALL PARTS ARE PRESENT. ASSISTANCE IS RECOMMENDED.

\*BODY FRAME MOUNT  
\*NO DRILLING REQUIRED

Fastener Size	Tightening Torque (ft-lbs)	Required
6mm	6-7	√
8mm	16-18	√
10mm	31-32	√
12mm	56-58	X
14mm	92-94	X

### PART LIST

Front  
↑

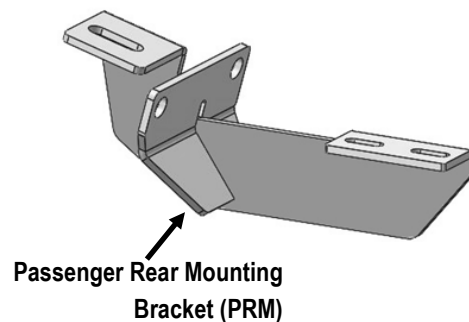
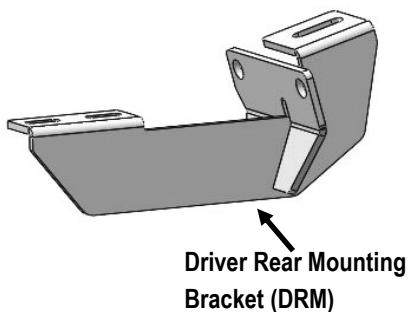
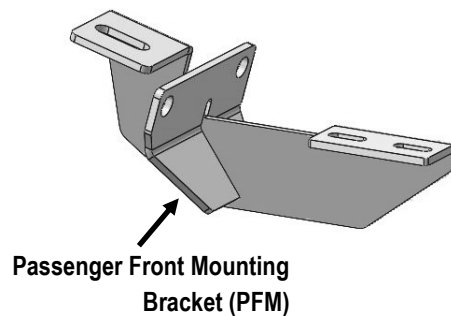
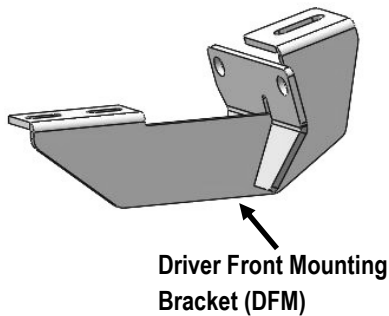

Customer Support: [info@iboardauto.com](mailto:info@iboardauto.com)

# iBoard®

## Hardware Package A (For Bracket Installation)

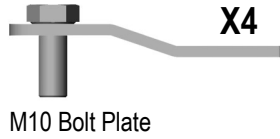

X4



X4



X4



X4



X8



X16



X8

## Hardware Package B (For Aluminum Step Bar Installation Only, Not Supply to Stainless Steel Step Bar)

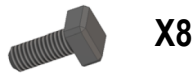

X8



X8



X8

## Hardware Package C (For Stainless Steel Step Bar Installation Only, Not Supply to Aluminum Step Bar)



X8



X8



X8

## STEP 1

Start installation from the driver side front of the vehicle. Insert (1) M10 Bolt Plate into the rectangular hole located in the side panel, and threaded M10 Bolt Plate drops through round hole (Fig 1).

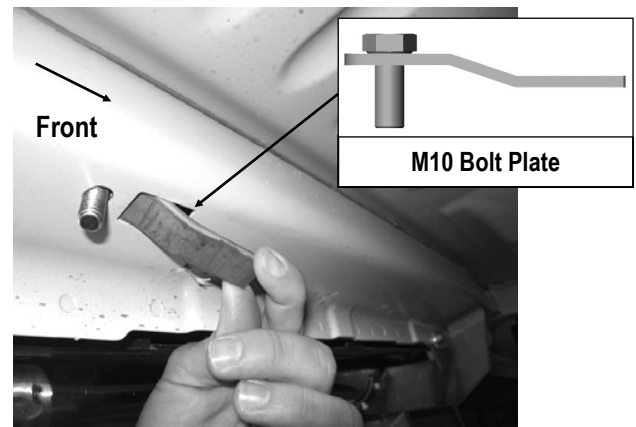

(Fig 1) Driver Side Front Mounting Location

# iBoard®

## STEP 2

Select the Driver Front Mounting Bracket (**DFM**). Attach the Driver Front Mounting Bracket (**DFM**) to the inserted M10 Bolt Plate with: (1) M10 Plastic Washer, (1) M10X1.5 Nylon Lock Nut and (1) M10 Flat Washer, (**Figs 3 & 4**). Do not fully tighten hardware at this time.

**Note:** Driver Side Mounting Brackets are not universal with Passenger Side Mounting Brackets, (**Fig 2**).

**NOTE:** the Driver Front Mounting Bracket is shorter than the Rear one. Make sure the 10mm mounting tab on the bracket faces the front of the vehicle.

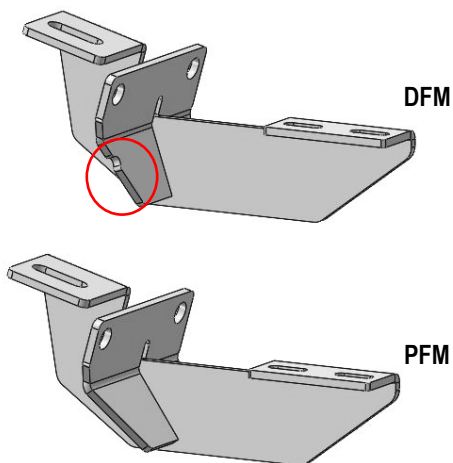
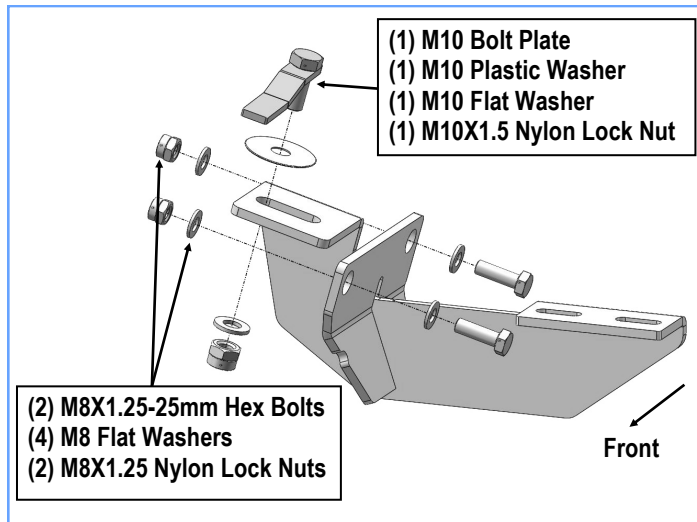

Fig 2

## STEP 3

Attach the Driver Front Mounting Bracket (**DFM**) to pinch weld using: (2) M8x1.25-25mm Hex Bolts, (2) M8 x1.25 Nylon Lock Nuts, and (4) M8 Flat Washers, (**Figs 3 & 4**). Do not fully tighten hardware at this time.

**Note:** Make sure that the vertical mounting plate on Bracket is on the outer side of the pinch weld.



(Fig 3) Driver Front Mounting Bracket Installation

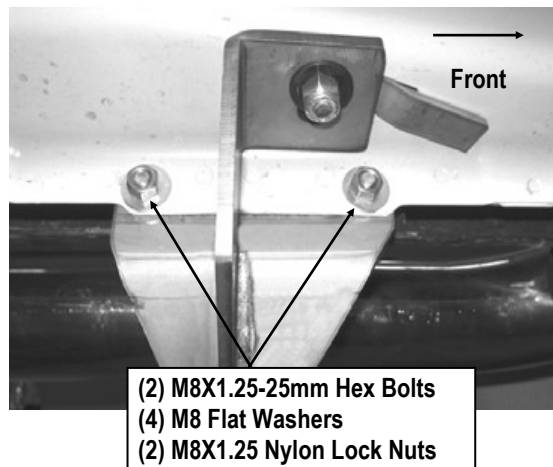

(Fig 4) Driver Front Mounting Bracket Installation

## STEP 4

Move to the driver side rear of the vehicle. Repeat **steps 1-3** to install the Driver Rear Mounting Bracket (**DRM**). Don't fully tighten hardware at this time.

# iBoard®

## STEP 5

Once all (2) mounting brackets are installed, then proceed to the Step Bar installation. According to the style of Step Bar proceed to the correct installation STEPS.

**Note: Aluminum Step Bar refer to STEP 6; Stainless Steel Step Bar skip to STEP 7.**

## STEP 6

### **Aluminum Step Bar Installation:**

Select a **Aluminum Step Bar**. Slip (2) M6x1-20mm Square Head Bolts into each bottom channel (**Fig 5**). Carefully position the Step Bar onto the (2) Mounting Brackets.

**IMPORTANT:** Do not slide the Step Bar on the Brackets or the bottom surface of the board will be damaged. Attach the Step Bar to each Mounting Brackets with (2) M6x1-20mm Square Head Bolts, (2) M6 Large Flat Washers and (2) M6X1 Nylon Lock Nuts, (**Fig 6**). Do not fully tighten at this time. Level and adjust the Step Bar and fully tighten all hardware. Repeat **Steps 1-6** for the other side Step Bar installation. **The installation is completed!!!**



(Fig 5) Slip M6X1-20mm Square Head Bolts Into The Bottom Channels

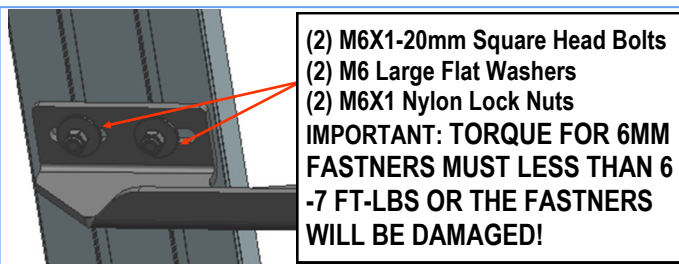

(Fig 6) Running Board Installed Onto Mounting Bracket

## STEP 7

### **Stainless Steel Step Bar Installation:**

Select a **Stainless Steel Step Bar** (with the U-Sliders installed on the Bar). Loose the U-Sliders, reposition the U-Sliders onto the board according to the (2) Installed Mounting Brackets location, (**Fig 7**). Re-secure the U-Sliders on the Step Bar. Attach the Step Bar to the installed Mounting Brackets with (4) M6X1-20mm Hex Bolts, (4) M6 Large Flat Washers & (4) M6 Lock Washers, (**Fig 8**). Do not fully tighten hardware at this time. Level and adjust the Step Bar and fully tighten all hardware. Repeat **Steps 1-5 and 7** for the other side Step Bar installation. **The installation is completed!!!**



(Fig 7) Slide & line up the U-Slider with the installed mounting brackets along bottom channel

(2) M6X1-20mm Hex Bolts  
(2) M6 Large Flat Washers  
(2) M6 Lock Washers  
**IMPORTANT: TORQUE FOR 6MM FASTNERS MUST LESS THAN 6-7 FT-LBS OR THE FASTNERS WILL BE DAMAGED!**



(Fig 8) Step Bar Installed On Bracket Installed

### **Attention**

Do periodic inspections to the installation to make sure that all hardware is secure and tight.

In order to protect your bars/boards, please use only mild soap/non-abrasive products for cleaning.