

iBoard®

iBoard® by APS

PART#: IB-R239/R313

READ INSTRUCTIONS CAREFULLY BEFORE STARTING INSTALLATION. REMOVE CONTENTS FROM BOX AND VERIFY ALL PARTS ARE PRESENT. ASSISTANCE IS RECOMMENDED.

*ROCKER PANEL MOUNT
*NO DRILLING REQUIRED

Fastener Size	Tightening Torque (ft-lbs)	Required
6mm	6-7	√
8mm	16-18	X
10mm	31-32	√
12mm	56-58	X
14mm	92-94	X

Item	QTY	Description	Item	QTY	Description
1#	1	Driver Front Mounting Bracket	6#	12	M10 Large Flat Washers
2#	1	Passenger Front Mounting Bracket	7#	12	M10 Lock Washers
3#	2	Driver Center/Rear Mounting Brackets	8#	12	M6X1-20mm Square Head Bolts
4#	2	Passenger Center/Rear Mounting Brackets	9#	12	M6 Large Flat Washers
5#	12	M10X1.5-25mm Hex Bolts	10#	12	M6 Nylon Lock Nuts

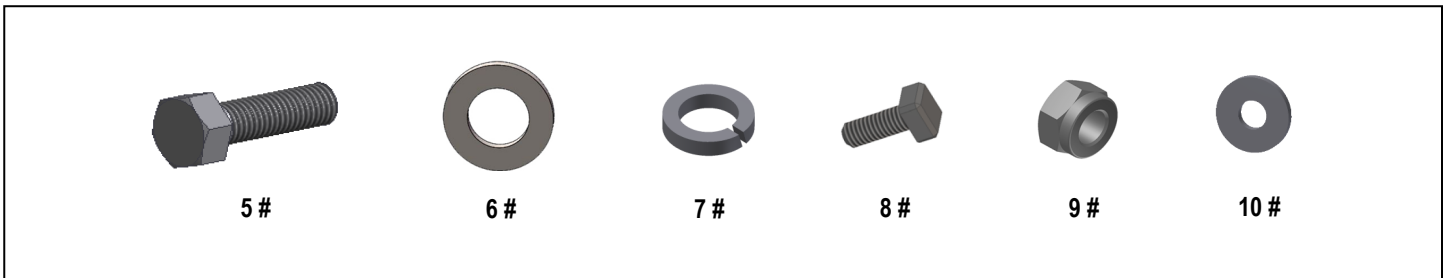

iBoard®

Driver

Front



Passenger

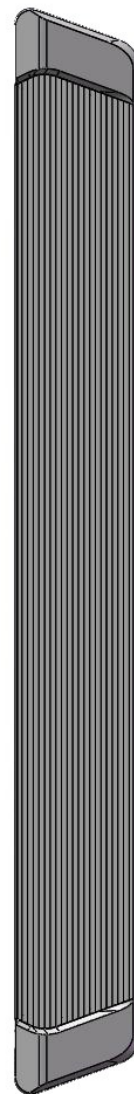
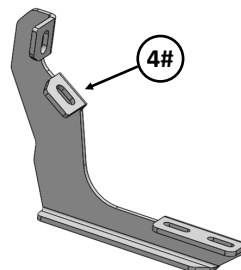
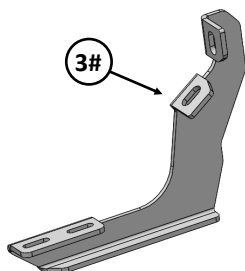
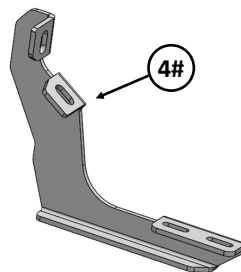
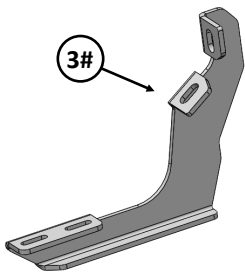
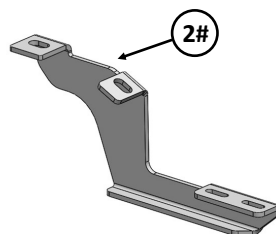
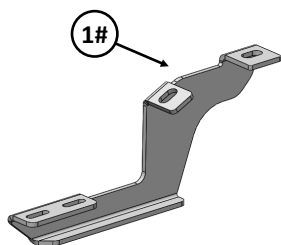

iBoard®

STEP 1

Start installation from the Passenger side front of the vehicle, locate the threaded mounting holes on the rocker panel, (**Fig 1**). Remove the plastic plugs covering the mounting holes.

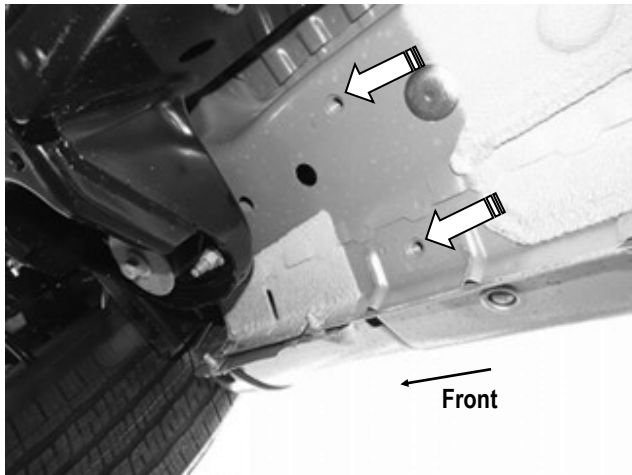

(Fig 1) Passenger Side Front Mounting Location

STEP 2

Select Passenger Front Mounting Bracket. Attach to Passenger side front mounting location with (2) M10x1.5-25mm Hex Bolts, (2) M10 Large Flat Washers and (2) M10 Lock Washers (**Fig 2**). Do not fully tighten hardware at this time.

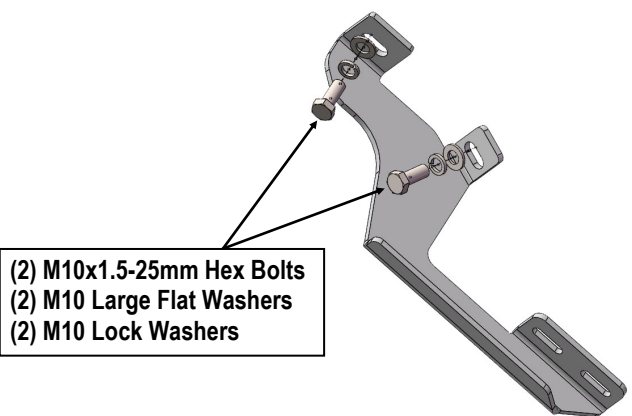

(Fig 2) Passenger Front Mounting Bracket Installed

STEP 3

Move to center & rear mounting locations, (**Fig 3-4**). Repeat **Steps 1-2** to installation Passenger Center & Rear Mounting Brackets.

Note: Passenger Center & Rear Mounting Bracket are universal .

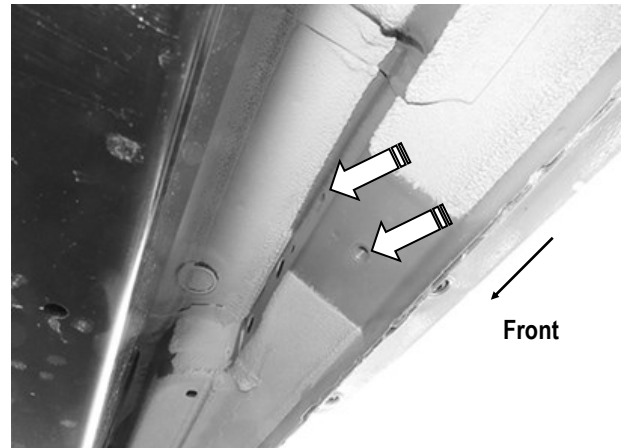

(Fig 3) Passenger Side Center Mounting Location

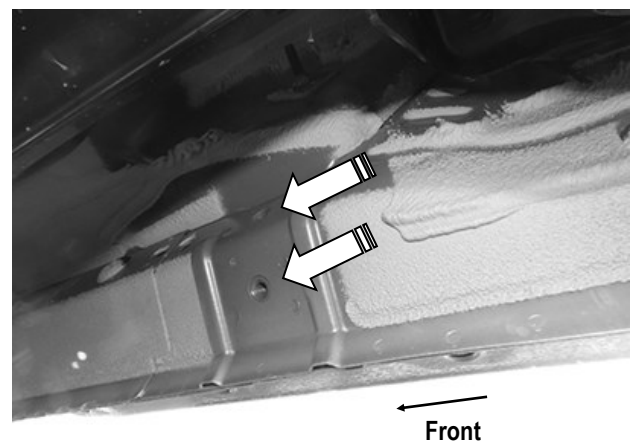

(Fig 4) Passenger Side Rear Mounting Location

iBoard®

STEP 4

Select a Running Board. Slip (3) M6x1-20mm Square Head Bolts into each bottom channel (**Fig 5**). Carefully position the Running Board onto the (3) Mounting Brackets.

IMPORTANT: Do not slide the Running Board on the Brackets or the bottom surface of the board will be damaged. Attach the Running Board to each Mounting Bracket with (2) M6x1-20mm Square Head Bolts, (2) M6 Large Flat Washers and (2) M6 Nylon Lock Nuts (**Fig 6**). Do not fully tighten at this time.

M6X1-20mm Square Head Bolts

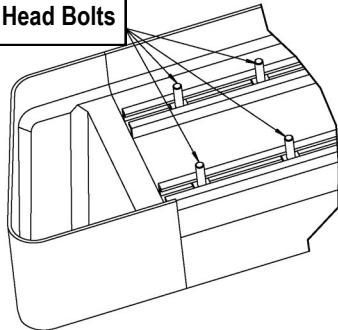

(Fig 5) Slip M6X1-20mm Square Head Bolts Into The Bottom Channels

(2) M6X1-20mm Square Head Bolts
(2) M6 Large Flat Washers
(2) M6 Nylon Lock Nuts

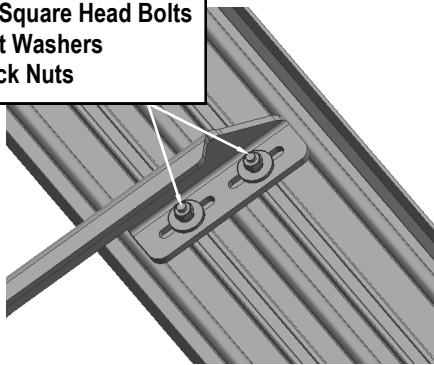

(Fig 6) Running Board Installed Onto Mounting Bracket

STEP 5

Level and adjust the Running Board and fully tighten all hardware.

Important: Please follow the recommended Tightening Torques shown in the table on page 1. Don't over tighten, or the nuts/bolts will be damaged.

STEP 6

Repeat **Steps 1-5** for the other side Running Board installation. The installation is completed.

Attention

Do periodic inspections to the installation to make sure that all hardware is secure and tight.

In order to protect your bars/boards, please use only mild soap/non-abrasive products for cleaning.