



SYSTEM #17171

1994-2001 DODGE RAM 1500 SERIES TRUCK
5.9L ENGINES - ALL WHEELBASES

12/01/09

Removal:

- 1) Disconnect the negative side of the battery cable. Raise the vehicle up on a hoist or rack to working height and support securely with jack stands.
- 2) Using a hacksaw or sawsall, cut the stock tailpipe off where it exits the muffler. (This step is mandatory, but makes removal much easier.)
- 3) Separate the two rubber hangers on the tailpipe, just behind the muffler, from their rubber mounts on the vehicle. Remove the two bolts at the rear of the tailpipe that connect the stock tailpipe hanger to the frame of the vehicle. Remove the tailpipe and set aside.
- 4) Support the muffler with a stand and remove the clamp in front of the muffler. Once the clamp is removed it may be necessary to heat this connection with a torch for ease of removal. Please use extreme caution when using a torch! If torching does not work, take a sawsall or hacksaw and cut muffler off right after hydro size on inlet pipe. Take a saw and slice excess off the inlet pipe.
- 5) Remove the muffler and set aside.

Installation:

- 1) Before installing anything, prep the clamps supplied in the hardware kit by removing the nuts, and applying a thick lubricant such as white grease or anti-seize to the threads.
- 2) Place inlet pipe **#TB230** in position on the front pipe from the catalytic converter, install one of the provided 2 1/2" clamps, but do not tighten yet.
- 3) Connect the inlet of the muffler **#530552** to the inlet pipe. Use a stand to support the muffler and install a 3" clamp, but do not tighten yet.
- 4) Due to the frame variations of model years, we have included two different rear tailpipe hangers for the left side of the vehicle. To determine which to use, look on drivers' side of the frame, just behind the rear wheel. Look for a larger slotted hole (small on 2000 model) with a smaller hole (1/4" dia.) about 1" below it. If these two holes are present, use hanger **#208HA**, with 5/16" bolt, nut and washer for the top hole and the 1/4" bolt, nut and washer for the bottom hole. If these holes are not there, look on the bottom edge of frame at about 18" forward of the rear bumper. There should be

two holes side-by-side at about 3/4" apart. Use hanger **#211HA**, with 5/16" bolt, nut and washer to mount the hanger to the forward hole. If you have an aftermarket tow hitch, such as Drawtite, etc., we have included two 5/16" shoulder bolts that will allow you to bolt rubber hanger **#HA168** directly to the side of the tow hitch. As the mounting arms of the hitch begin to narrow toward the front of the vehicle, there will be two holes located on the side of the hitch. Place **#HA168** up to the forward hole and insert the shoulder bolt with the 3/8" washer through **#HA168** from the inside of the hitch. Use the 5/16" lock washer and nut to secure the hanger into place. Repeat this step for the passenger side of the vehicle.

5) Take the two rubber hangers **#HA168** and slide them onto the bottom of either **#208HA** or **#211HA**. Then take the clamp hangers **#209HA** and slide them into the bottom of rubber hanger **#HA168**. The kit diagram shows which way to insert the hangers.

6) Place right side tailpipe **#16127** in position over the axle and slip into the right side muffler outlet and insert the hanger into the right rubber hanger mount on the frame. Place the rear of the tailpipe into the 2 1/2" clamp hanger.

7) Place the front section of the left side tailpipe **#16128** into the left side muffler outlet and insert hanger into the left rubber hanger mount on the frame.

8) Connect the rear section of the left side tailpipe **#16124** onto the back of the front section by sliding the two sections together at the slip-fit connection over the rear axle. Place the rear of the tailpipe into the 2 1/2" clamp hanger and install a 2 1/2" clamp on the over-axle slip-fit connection.

9) Slide exit pipe **#16123** for the both the right and left side through the clamp hangers and onto the back of the tailpipes. Adjust the position of the tailpipes and tighten the clamp assemblies enough to hold them in place.

10) Adjust the position of all pipes and muffler and tailpipe to provide a satisfactory fit. Maintain a minimum of 3/4" clearance around all parts of the system; while keeping suspension travel and vibration in mind.

11) Tighten down all clamped connections securely. Slide the 7/16" hanger keepers onto the end of the two hangers behind the muffle rand also onto all round hanger mounts. These will prevent the rubber hangers from sliding off.

12) For a cleaner appearance and more secure installation, we highly recommend welding all slip-fit connections. If you live in a geographical area that has harsh winters or sees a great deal of precipitation, the use of temperature paint over the welded areas can help to prevent surface rust and premature corrosion.

PACKING LIST

<u>Qty</u>	<u>Description</u>	<u>Part#</u>
1	Adapter pipe	TB230
1	Muffler	530552
1	Tailpipe (R)	16127
1	Tailpipe (Front L)	16128
1	Tailpipe (Rear L)	16124
2	Exit Pipe (L/R)	16123
1	Parts kit	PK302
4	2 ½" clamp	MC250S
1	3" clamp	MC300G
2	Frame Hanger	208HA
2	Clamp Hanger	209HA
1	Frame Hanger	211HA
2	Rubber hanger	HA168
2	5/16" x 1" Bolt	
2	5/16" Nut	
2	5/16" lock washer	
2	1/4" x 1" Bolts	
2	1/4" Lock Washers	
2	1/4" Nuts	
6	7/16" Hanger Keepers	
2	3/8" X 1 3/4" Shoulder Bolts	
2	3/8" Flat Washers	



Installation diagram for:
SYSTEM #17171
1994-2001 DODGE RAM 1500 SERIES TRUCK
5.9L ENGINES • ALL WHEELBASES

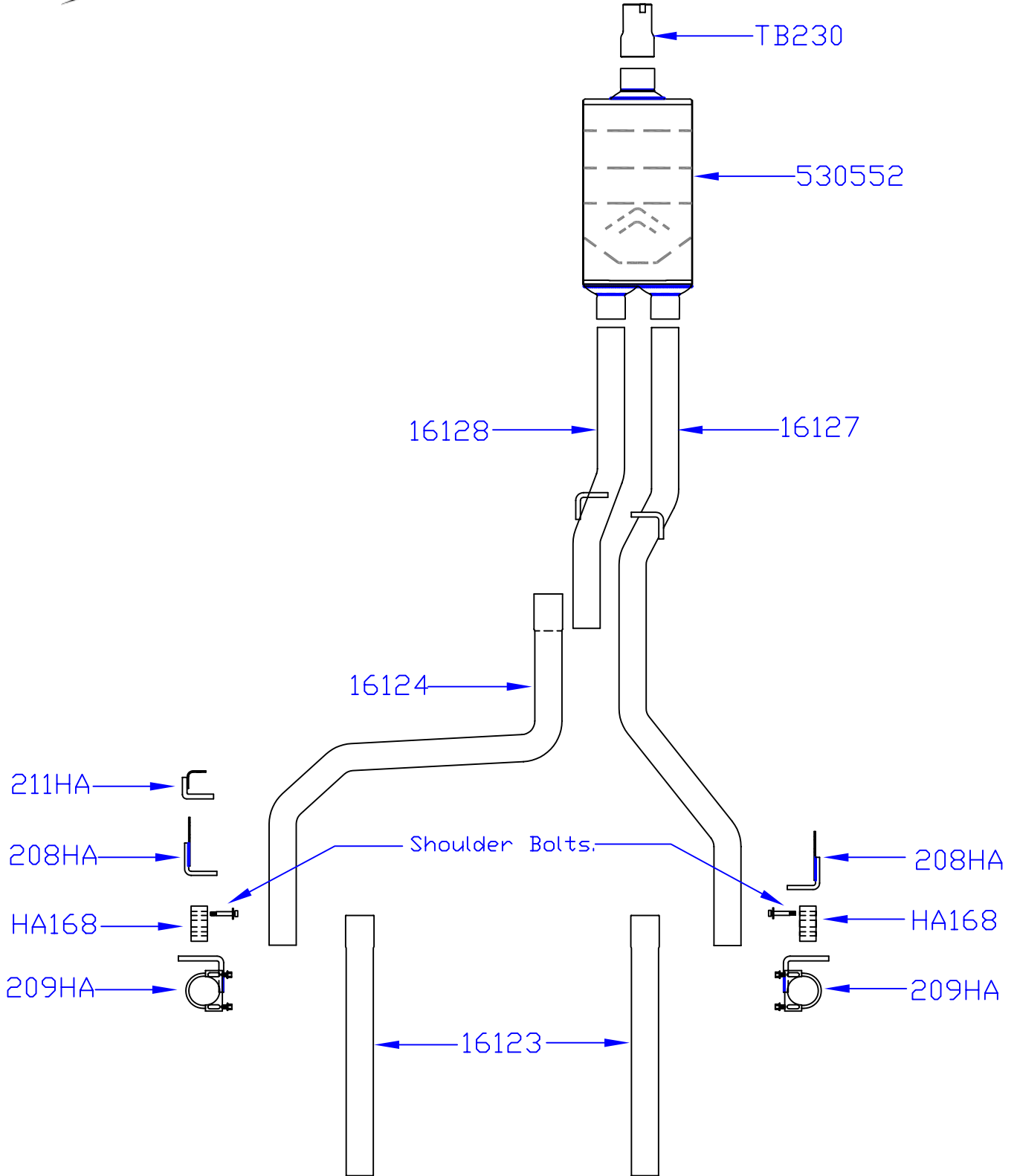

Technical Support (800) 544-4761