



TYPHOON INTAKE SYSTEMS

INTAKE SYSTEMS FOR VEHICLES LISTED ARE 50 STATE LEGAL. SEE KNFILTERS.COM FOR CARB STATUS ON EACH PART FOR A SPECIFIC VEHICLE.

INSTALLATION INSTRUCTIONS

69-1213TS HONDA 2013-14 Accord L4-2.4L

NOTE: Excludes LEV2 SULEV 2013-2014
Test Groups: DHNXV02.4NC3, EHNXV02.46C3

TOOLS NEEDED:

- Ratchet
- Extension
- 10mm socket
- 12mm wrench
- flat blade screw driver,
- Pliers
- Phillips screw driver
- 3mm allen key

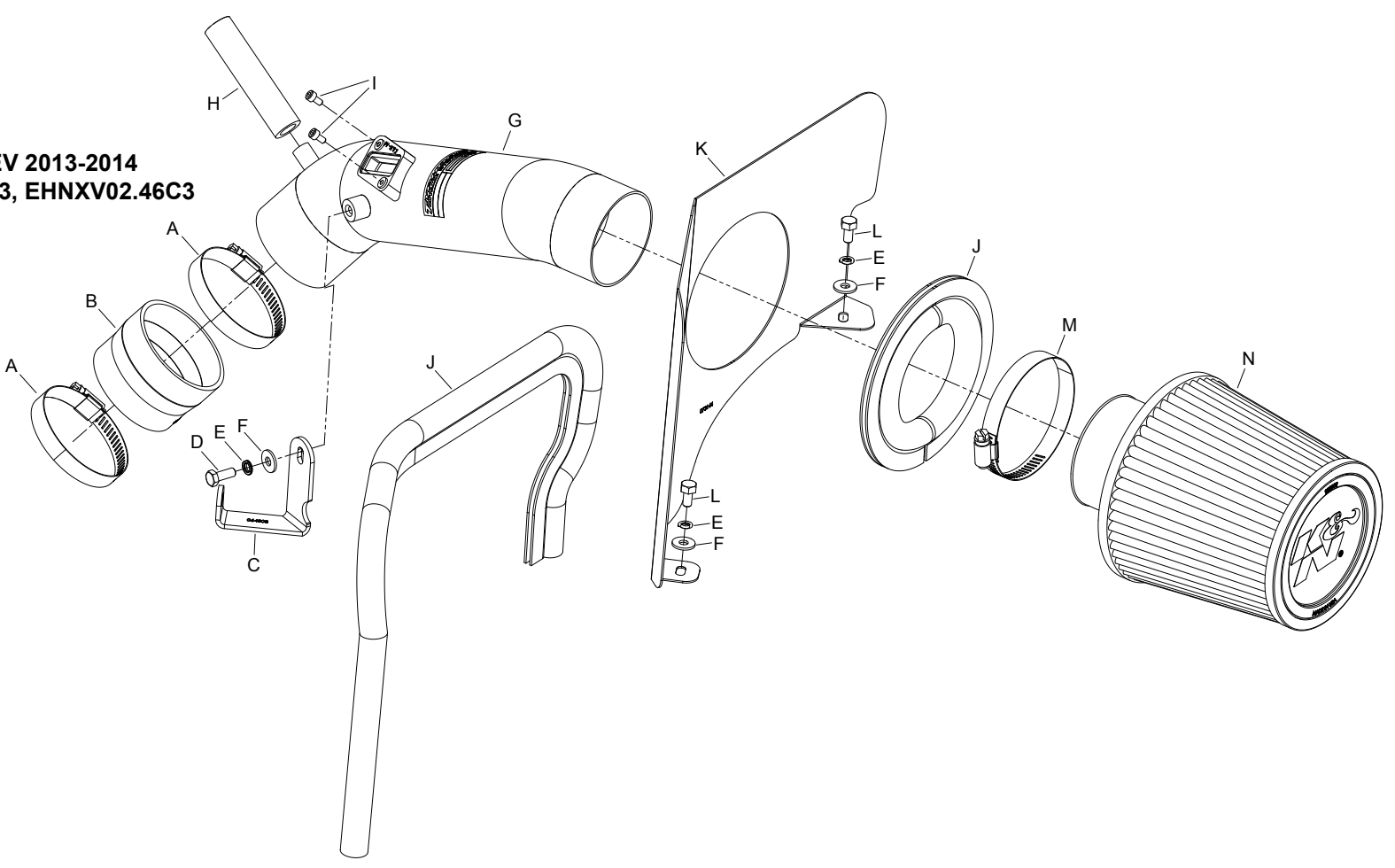

PARTS LIST:

Description	Qty.	Part #	Description	Qty.	Part #	Description	Qty.	Part #
A Hose Clamp #40	2	08554	F Washer; 6MM Flat, SS	3	08269	K Heat Shield	1	073144
B Hose; 2-3/4" To 2-5/8"ID X 2"L	1	084014	G Intake Tube	1	27344TS	L Bolt; M6 X 1.00 X 12MM, SS	2	07727
C Bracket; "C", 69-1213, STL	1	064308	H Hose; 1/2"ID X 3-1/2"L	1	087028	M Hose Clamp #44	1	08577
D Bolt; 6MM-1.00 X 16MM, SS	1	07812	I Bolt; M4-0.07 8MM, A/H Cap, SS	2	07733	N Air Filter	1	RU-4960XD
E Washer; M6 Split Lock Zinc	3	1-3025	J Edge Trim (44")	1	102486			

NOTE: FAILURE TO FOLLOW INSTALLATION INSTRUCTIONS AND NOT USING THE PROVIDED HARDWARE MAY DAMAGE THE INTAKE TUBE, THROTTLE BODY AND ENGINE.

TO START:

1. Turn off the ignition and disconnect the negative battery cable.
NOTE: Disconnecting the negative battery cable erases pre-programmed electronic memories. Write down all memory settings before disconnecting the negative battery cable. Some radios will require an anti-theft code to be entered after the battery is reconnected. The anti-theft code is typically supplied with your owner's manual. In the event your vehicles anti-theft code cannot be recovered, contact an authorized dealership to obtain your vehicles anti-theft code.



2. Disconnect the mass air sensor electrical connection and unhook the wiring harness from the air box.



3. Release the spring clamp securing the crank case vent pipe to the factory intake tube and then disconnect the vent pipe from the intake tube.



4. Loosen the hose clamp that secures the factory intake tube to the throttle body.



5. Loosen and remove the two bolts securing the factory air box.



6. Remove the complete factory intake system from the vehicle.
NOTE: K&N Engineering, Inc., recommends that customers do not discard factory air intake.

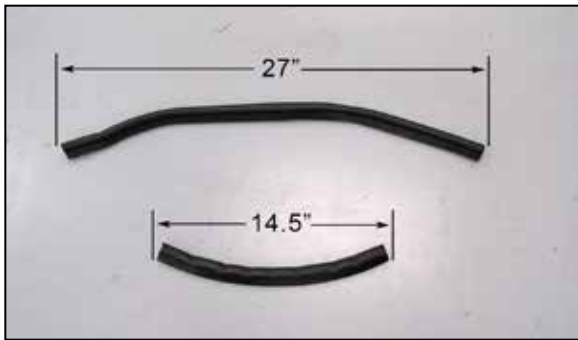

7. Cut the provided edge trim into two sections, one section will be 27" long and one section will be 14-1/2" long.

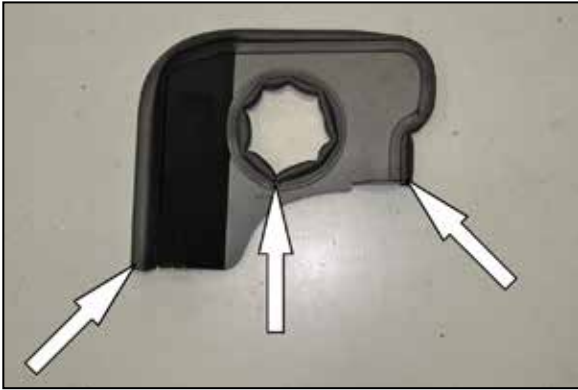

8. Install the edge trim into the hole and around the outside of the heat shield as shown.



9. Install the heat shield onto the factory air box mounting locations and secure with the provided hardware.



10. Install the provided silicone hose (084014) onto the throttle body and secure with the provided hose clamp.



11. Remove the two screws securing the mass air sensor and then remove the mass air sensor from the vehicle.



12. Install mass air sensor into the K&N® intake tube and secure with the provided hardware.



13. Remove the bolt shown from the engine; this bolt will be reused in the next step.



14. Install the provided tube mounting bracket (064308) onto the engine as shown using the bolt from the previous step.



15. Install the K&N® intake tube through the heat shield, into the silicone hose at the throttle body and align with the mounting bracket. Secure the tube with the provided hardware and hose clamp.

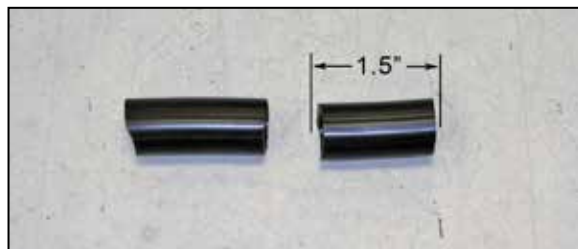

16. Cut the provided crank case vent hose to a length of 1-1/2" long as shown.



17. Connect the factory crank case vent pipe to the K&N® intake tube using the 1-1/2" long section of crank case vent hose from the previous step.



18. Install the K&N® air filter onto the K&N® intake tube and secure with the provided hose clamp



19. Reconnect the mass air sensor electrical connection.



20. Reconnect the vehicle's negative battery cable. Double check to make sure everything is tight and properly positioned before starting the vehicle.

21. The C.A.R.B. exemption sticker, (attached), must be visible under the hood so that an emissions inspector can see it when the vehicle is required to be tested for emissions. California requires testing every two years, other states may vary.

22. It will be necessary for all K&N® high flow intake systems to be checked periodically for realignment, clearance and tightening of all connections. Failure to follow the above instructions or proper maintenance may void warranty.

ROAD TESTING:

1. Start the engine with the transmission in neutral or park, and the parking brake engaged. Listen for air leaks or odd noises. For air leaks secure hoses and connections. For odd noises, find cause and repair before proceeding. This kit will function identically to the factory system except for being louder and much more responsive.

2. Test drive the vehicle. Listen for odd noises or rattles and fix as necessary.

3. If road test is fine, you can now enjoy the added power and performance from your kit.

4. K&N Engineering, Inc., requires cleaning the intake system's air filter element every 100,000 miles. When used in dusty or off-road environments, our filters will require cleaning more often. We recommend that you visually inspect your filter once every 25,000 miles to determine if the screen is still visible. When the screen is no longer visible some place on the filter element, it is time to clean it. To clean and re-oil, purchase our filter Recharger® service kit, part number 99-5050 or 99-5000 and follow the easy instructions.

INTAKE SYSTEMS FOR VEHICLES LISTED ARE 50 STATE LEGAL. SEE KNFILTERS.COM FOR CARB STATUS ON EACH PART FOR A SPECIFIC VEHICLE.