



TYPHOON INTAKE SYSTEMS

INTAKE SYSTEMS FOR VEHICLES LISTED ARE 50 STATE LEGAL. SEE KNFILTERS.COM FOR CARB STATUS ON EACH PART FOR A SPECIFIC VEHICLE.

INSTALLATION INSTRUCTIONS

69-7061TS

NISSAN

2007-12 Altima

2013 Altima Coupe

L4-2.5L

TOOLS NEEDED:

- Flat Blade Screwdriver
- Phillips Screwdriver
- Ratchet
- Extension
- 8mm Socket
- 10mm Socket
- 3mm Allen
- 5mm Allen
- 10mm Wrench

NOTE: EXCLUDING LEV2 SULEV
2007-11 TEST GROUPS 7NSXV02.585A,
8NSXV02.585A, 9NSXV02.585A,
ANSXV02.585A & BNSXV02.585A

NOTE: EXCLUDING HYBRID

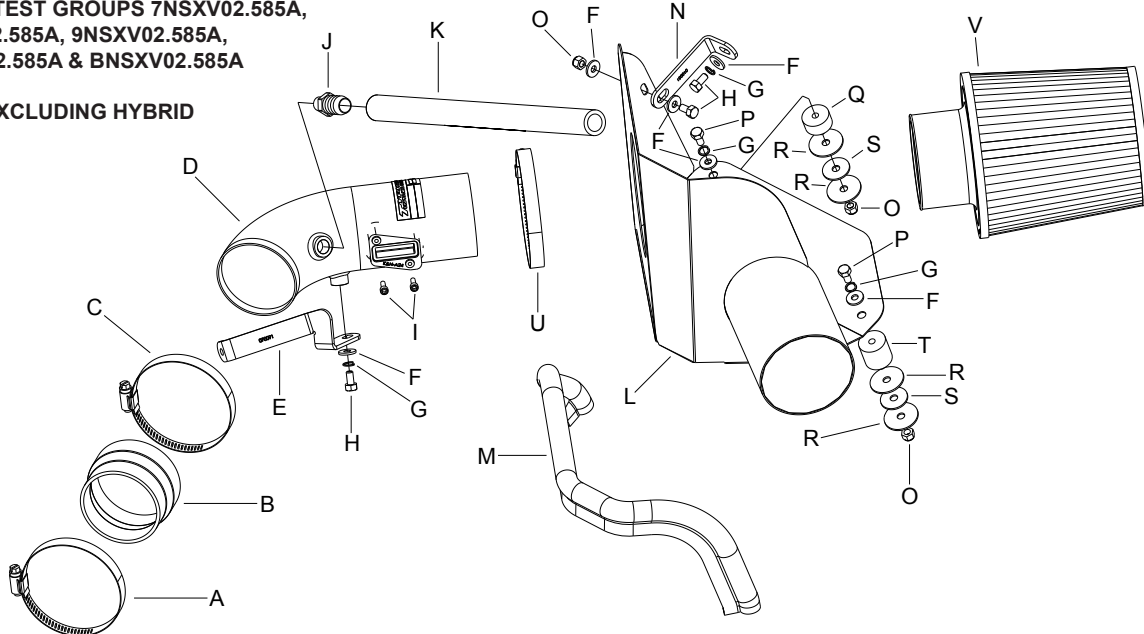

PARTS LIST:

Desc.	Qty.	Part #
A	1	08554
B	1	084036
C	1	08560
D	1	27520TS
E	1	070091
F	6	08275
G	4	08198
H	3	07812
I	2	07733
J	1	08911
K	1	084083
L	1	07691
M	1	102494
N	1	010051
O	3	07512
P	2	07727
Q	1	070228
R	4	08151
S	2	21685
T	1	02033
U	1	08610
V	1	RU-4990

NOTE: FAILURE TO FOLLOW INSTALLATION INSTRUCTIONS AND NOT USING THE PROVIDED HARDWARE MAY DAMAGE THE INTAKE TUBE, THROTTLE BODY AND ENGINE.

TO START:

1. Turn off the ignition and disconnect the negative battery cable.

NOTE: Disconnecting the negative battery cable erases pre-programmed electronic memories. Write down all memory settings before disconnecting the negative battery cable. Some radios will require an anti-theft code to be entered after the battery is reconnected. The anti-theft code is typically supplied with your owner's manual. In the event your vehicles' anti-theft code cannot be recovered, contact an authorized dealership to obtain your vehicles anti-theft code.



2. Disconnect the mass air sensor electrical connection and then unhook the wiring harness clips from the air box.



3. Remove three bolts which secure the engine cover and then remove the engine cover.

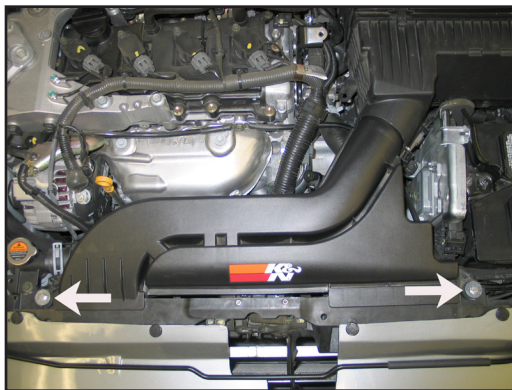

4. Remove the two bolts that secure the fresh air inlet assembly.



5. Remove the fresh air inlet assembly from the air box and radiator core support.



6. Release crank case vent hose spring clamp and then disconnect the crank case vent hose from the intake tube.



7. Loosen the hose clamp which secures the intake hose to the throttle body and remove the air box mounting bolt.

NOTE: The mounting bolt is located next to the strut tower towards the bottom of the air box.



8. Remove the air box assembly from the vehicle. **NOTE: K&N Engineering, Inc., recommends that customers do not discard factory air intake.**

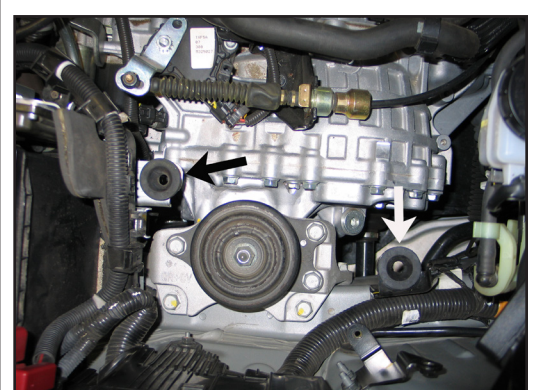

9. Remove the two rubber air box mounting grommets shown.

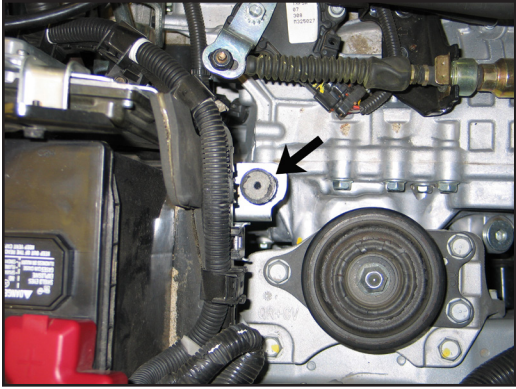

10. Install the 1.0" high rubber mounted stud onto the front air box mounting location using the provided hardware.

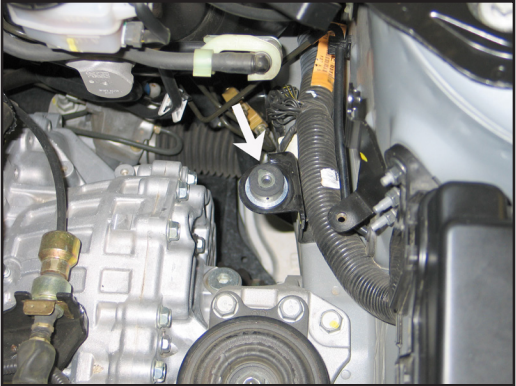

11. Install the 1/2" high rubber mounted stud onto the rear air box mounting location using the provided hardware.

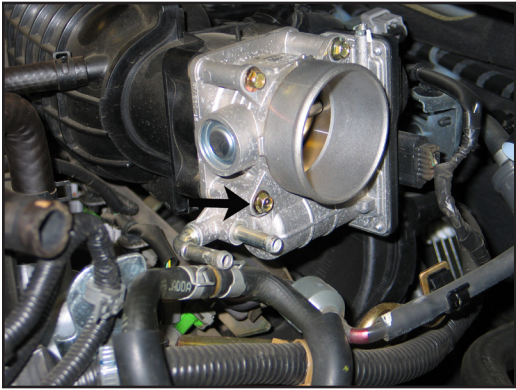

12. Remove the lower-front throttle body mounting bolt.
NOTE: This bolt will be reused in the next step.



13. Install the tube mounting bracket (070091) onto the throttle body using the bolt removed in the previous step.



14. Install the provided silicone hose (084036) onto the throttle body and secure with the provided hose clamp.



15. Install the provided 1/4" npt vent fitting into the K&N® Intake Tube as shown.
NOTE: Plastic NPT fittings are easy to cross thread. Install the vent fitting "hand" tight, then turn it two complete turns with a wrench.

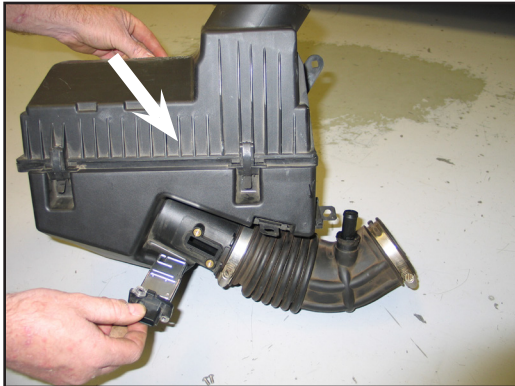

16. Remove the two bolts which secure the mass sensor to the intake tube and remove the mass air sensor as shown.



17. Install the mass air sensor into the K&N® intake tube and secure with the provided hardware.



18. Install the K&N® intake tube into the silicone hose at the throttle body and align with the mounting bracket. Secure with the provided hardware and hose clamp.

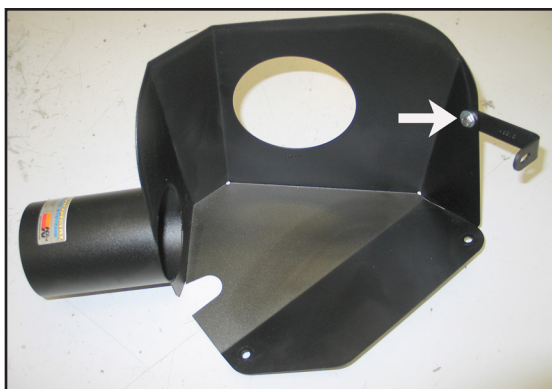

19. Install the heat shield mounting bracket (010051) onto the heat shield as shown using the provided hardware.

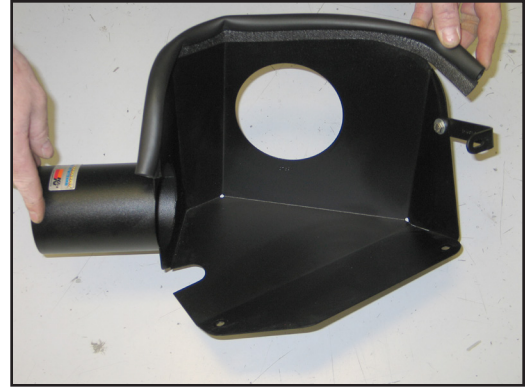

20. Install the provided edge trim onto the heat shield as shown.
NOTE: Some trimming of the edge trim will be necessary.

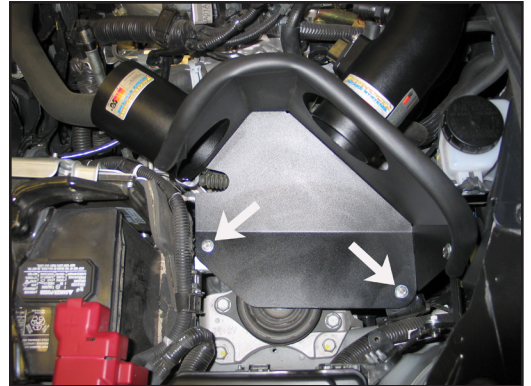

21. Install the heat shield into the vehicle so the mounting holes line up with the rubber mounted studs installed earlier. Secure the heat shield and mounting bracket with the hardware provided.



22. Reinstall the fresh air inlet supply to the original location and into the fresh air tube on the heat shield then secure with the factory bolts.

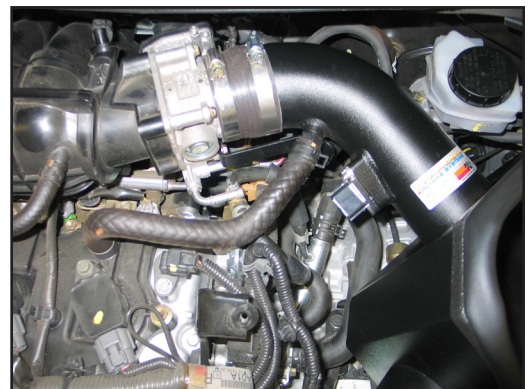

23. Install the factory crank case vent hose to the 1/4" npt vent installed onto the K&N® intake tube.



24. Reconnect the mass air sensor electrical connection.

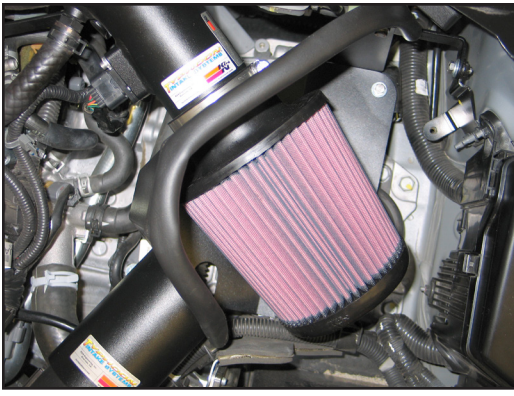

25. Install the K&N® air filter onto the K&N® intake tube and secure with the provided hose clamp.

NOTE: Drycharger® air filter wrap; part # RU-4990DK is available to purchase separately. To learn more about Drycharger® filter wraps or look up color availability please visit <http://www.knfilters.com>.



26. Reinstall the engine cover and secure with the factory bolts.



27. Reconnect the vehicle's negative battery cable. Double check to make sure everything is tight and properly positioned before starting the vehicle.

28. This K&N® high flow intake system has been designed to be used in two different configurations. In the case of inclement weather, the cold air tube can be removed and the air filter can be clamped onto the intake tube located in the engine compartment to avoid the possibility of ingesting water into the engine.

NOTE: If you have any concerns, return the vehicle to stock using the factory equipment.

29. The C.A.R.B. exemption sticker, (attached), must be visible under the hood so that an emissions inspector can see it when the vehicle is required to be tested for emissions. California requires testing every two years, other states may vary.

30. It will be necessary for all K&N® high flow intake systems to be checked periodically for realignment, clearance and tightening of all connections. Failure to follow the above instructions or proper maintenance may void warranty.

ROAD TESTING

1. Start the engine with the transmission in neutral or park, and the parking brake engaged. Listen for air leaks or odd noises. For air leaks secure hoses and connections. For odd noises, find cause and repair before proceeding. This kit will function identically to the factory system except for being louder and much more responsive.

2. Test drive the vehicle. Listen for odd noises or rattles and fix as necessary.

3. If road test is fine, you can now enjoy the added power and performance from your kit.

4. K&N® suggests checking the air filter element periodically for excessive dirt build-up. When the element becomes covered in dirt (or once a year), service it according to the instructions on the Recharger service kit, part number 99-5050 or 99-5000.

INTAKE SYSTEMS FOR VEHICLES LISTED ARE 50 STATE LEGAL. SEE KNFILTERS.COM FOR CARB STATUS ON EACH PART FOR A SPECIFIC VEHICLE.