



TYPHOON INTAKE SYSTEMS

SOME INTAKE SYSTEMS ARE NOT LEGAL FOR SALE OR USE ON ANY POLLUTION CONTROLLED MOTOR VEHICLE IN CALIFORNIA OR STATES ADOPTING CALIFORNIA EMISSION PROCEDURES. See knfilters.com for CARB status on each part for a specific vehicle

INSTALLATION INSTRUCTIONS

69-9503TFK

AUDI

2003-08 A3 (Europe)

2006-07 A3 (US)

L4-2.0L Turbo

VOLKSWAGEN

2005-07 Golf V

2006-07 Jetta GLI

2006-07 Jetta (Europe)

2006-08 GTi

L4-2.0L Turbo

SEAT

2006-08 Altea / Leon II / Toledo

L4-2.0L Turbo

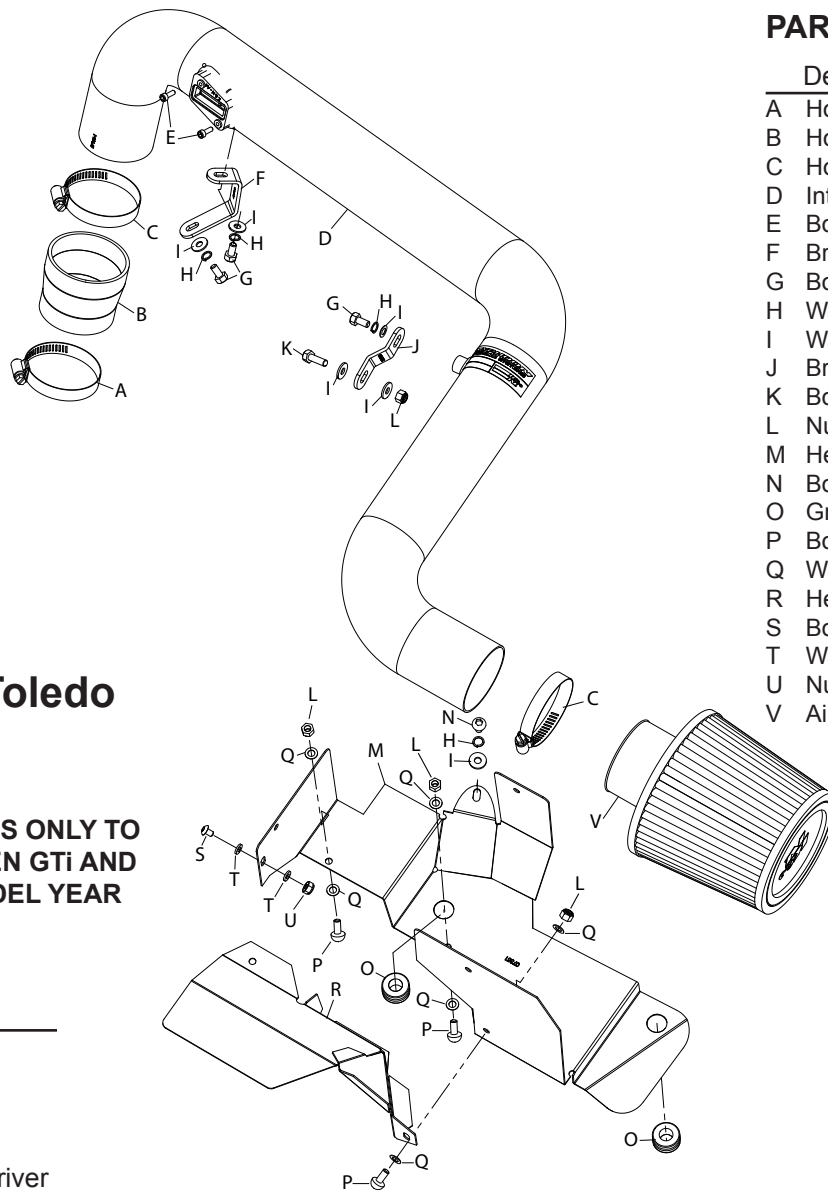

PARTS LIST

Description	Qty.	Part #
A Hose Clamp #36	1	08530
B Hose; 2-1/2" to 2-3/4" TPRD; Black	1	084016
C Hose Clamp #44	2	08560
D Intake Tube	1	27156-1
E Bolt; M4 - 0.07 8mm, A/H Cap, SS	2	07733
F Bracket; "C", TK/PC	1	070107
G Bolt; M6 X 1.00 X 16mm, Hex, SS	3	07812
H Washer; 1/4" Lock, ZN	4	08198
I Washer; 1/4"ID X 5/8"OD	6	08275
J Bracket; "Z", STL, TK/PC	1	010038
K Bolt; M6 X 1.00 X 20mm, Hex, SS	1	07795
L Nut; 6mm Nylock, Hex Head, SS	4	07512
M Heat Shield; Large	1	07351
N Bolt; M6 X 1.00 X 16mm, Button Head, SS	1	07730
O Grommet; 1"OD, 1/2"ID, 1/2"THK	2	08064
P Bolt; M6 X 1.00 X 12mm, Button Head, SS	3	07794
Q Washer; 6mm Flat, SS	6	08269
R Heat Shield, Small	1	07350
S Bolt; M5 X .8 X 12mm, Button Head, SS	1	07734
T Washer; 5mm Flat, SS	2	08212
U Nut; M5 - 0.8, Nylock, SS	1	07507
V Air Filter	1	RU-4960

NOTE: C.A.R.B. E.O. # D-269-37 APPLIES ONLY TO 2006-07 AUDI A3, 2006-08 VOLKSWAGEN GTi AND 2006-07 VOLKSWAGEN JETTA GLI MODEL YEAR VEHICLES

TOOLS NEEDED:

- 3MM Allen Wrench
- 4mm Allen Wrench
- 8MM Socket
- 10MM Socket
- 10MM Wrench
- Pliers
- Ratchet
- Extension
- T20 Torx Socket
- Flat Blade Screwdriver

NOTE: FAILURE TO FOLLOW INSTALLATION INSTRUCTIONS AND NOT USING THE PROVIDED HARDWARE MAY DAMAGE THE INTAKE TUBE, THROTTLE BODY AND ENGINE.

TO START:

1. Turn off the ignition and disconnect the negative battery cable.

NOTE: Disconnecting the negative battery cable erases pre-programmed electronic memories. Write down all memory settings before disconnecting the negative battery cable. Some radios will require an anti-theft code to be entered after the battery is reconnected. The anti-theft code is typically supplied with your owner's manual. In the event your vehicles' anti-theft code cannot be recovered, contact an authorized dealership to obtain your vehicles anti-theft code.



2. Disconnect the mass air sensor electrical connection and unhook the mass air sensor wiring from the engine cover.



3. Remove the two screws shown that secure the fresh air tube to the fresh air duct.



4. Pull up firmly on the air filter housing/engine cover assembly to release it from the mounting grommets.

NOTE: The air filter housing/engine cover assembly is still attached to the intake inlet tube.



5. Using pliers, release the spring clamp that secures the intake to the intake inlet. Then unhook the intake tube from the inlet. NOTE: K&N Engineering, Inc., recommends that customers do not discard factory air intake.



6. Remove the air filter housing/engine cover assembly from the vehicle.

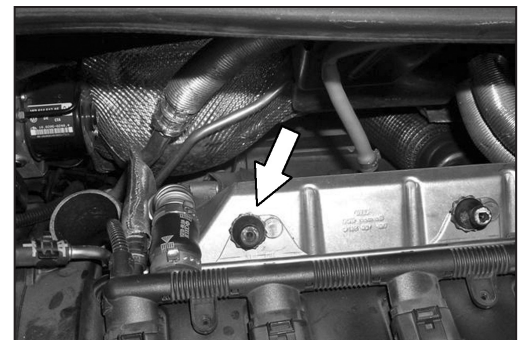

6a. Remove the airbox mounting stud shown



7. Remove the upper fresh air duct cover as shown.

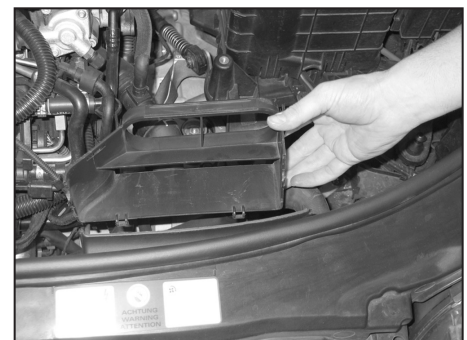

8. Unsnap and remove the lower fresh air duct as shown.

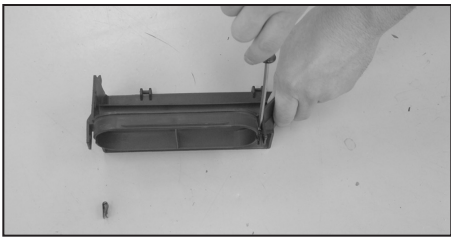

9. Using a small screw driver remove the two clip nuts from the lower fresh air duct as shown.

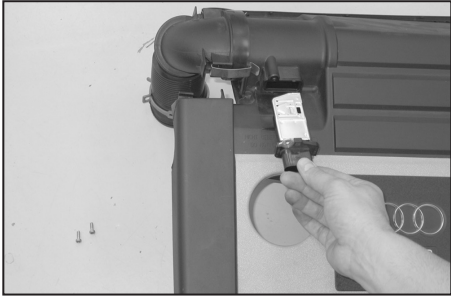

10. Remove the two screws that secure the mass air sensor to the stock air filter housing and then remove the mass air sensor as shown.



11. Install the mass air sensor into the K&N® intake tube with the provided hardware.



11a. Install the tube mounting bracket (070107) onto the K&N® intake tube and secure with the provided hardware.

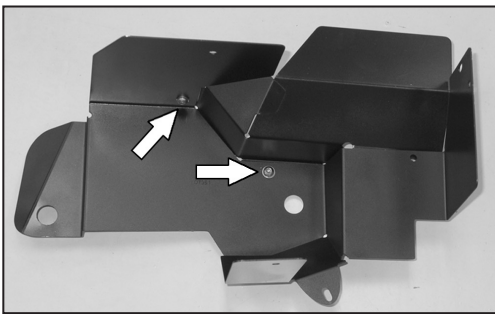

12. Install heat shield #07350 onto heat shield #07351 and secure with provided hardware.
NOTE: Do not completely tighten at this time.
NOTE: Ensure the provided hardware is assembled so the button head side of the bolt faces the outer side of the heat shield.

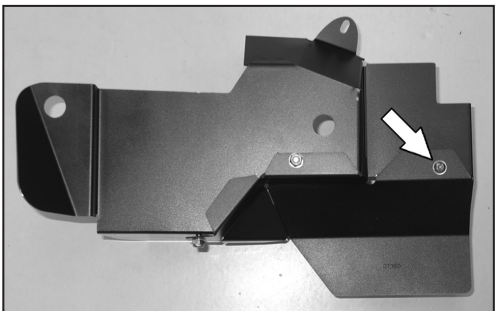

13. Install the third bolt to secure heat shield #07350 to heat shield #07351 from the bottom side as shown. Completely tighten all three bolts.
NOTE: Ensure the provided hardware is assembled so the button head side of the bolt faces the outer side of the heat shield.

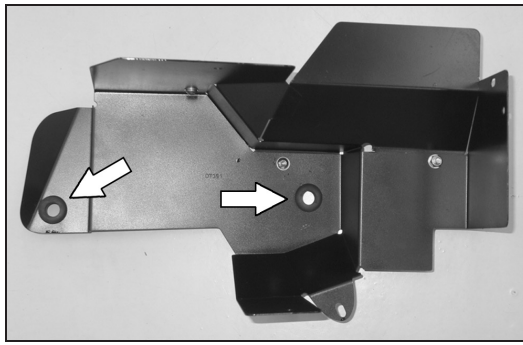

14. Install the two heat shield mounting grommets into the mounting holes as shown.

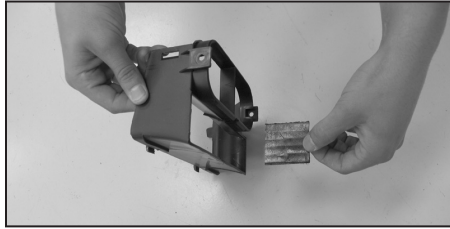

15. On 2007 and later models, it will be necessary to cut and remove the divider from the fresh air inlet tube as shown.

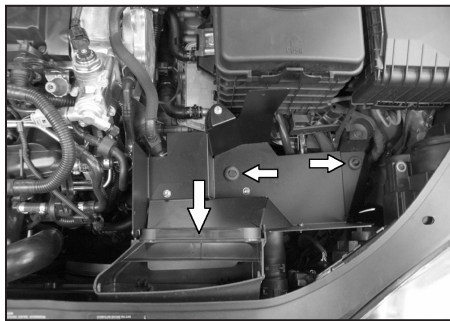

16. Install the heat shield assembly and fresh air duct into the vehicle so that the heat shield mounting grommets are snapped onto the mounting studs and the fresh air duct snaps into the fresh air supply tube, secure the duct and heat shield with the provided hardware.
NOTE: Be sure to snap the lower fresh air duct into the fresh air supply tube. The fresh air duct will bolt to the heat shield.

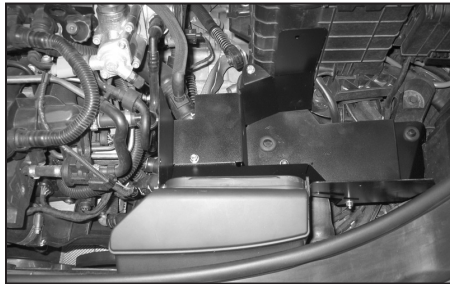

17. Install the upper fresh air duct cover as shown.



18. Install the provided silicone hose (084016) onto the turbo inlet and secure with the provided hose clamp.

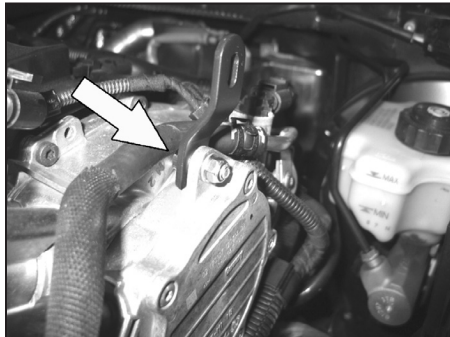

19. Install the tube mounting bracket (010038) onto the left side of the engine cylinder head as shown and secure with the provided hardware.
NOTE: Do not completely tighten at this time.

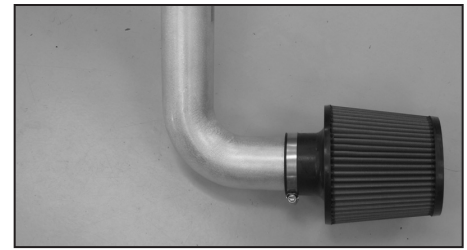

20. Install the K&N® air filter onto the K&N® intake tube and secure with the provided hose clamp



21. Install the K&N® intake tube into the silicone hose at the turbo inlet and align with the bracket installed during step 19. Secure the bracket attached to the intake tube (070107) to the airbox mounting location. Secure the intake tube with the provided hose clamp and hardware.



22. Reconnect the mass air sensor electrical connection as shown.



23. Reconnect the vehicle's negative battery cable. Double check to make sure everything is tight and properly positioned before starting the vehicle.

24. The C.A.R.B. exemption sticker, (attached), must be visible under the hood so that an emissions inspector can see it when the vehicle is required to be tested for emissions. California requires testing every two years, other states may vary.

25. It will be necessary for all K&N® high flow intake systems to be checked periodically for realignment, clearance and tightening of all connections. Failure to follow the above instructions or proper maintenance may void warranty.

ROAD TESTING:

1. Start the engine with the transmission in neutral or park, and the parking brake engaged. Listen for air leaks or odd noises. For air leaks secure hoses and connections. For odd noises, find cause and repair before proceeding. This kit will function identically to the factory system except for being louder and much more responsive.
2. Test drive the vehicle. Listen for odd noises or rattles and fix as necessary.
3. If road test is fine, you can now enjoy the added power and performance from your kit.
4. K&N Engineering, Inc., suggests checking the air filter element periodically for excessive dirt build-up. When the element becomes covered in dirt (or once a year), service it according to the instructions on the Recharger® service kit, part number 99-5050 or 99-5000.

SOME INTAKE SYSTEMS ARE NOT LEGAL FOR SALE OR USE ON ANY POLLUTION CONTROLLED MOTOR VEHICLE IN CALIFORNIA OR STATES ADOPTING CALIFORNIA EMISSION PROCEDURES.

See knfilters.com for CARB status on each part for a specific vehicle