



## Installation Instructions

For Part Numbers:

200-250	720-472 Airaid Oiled Media Filter
201-250	721-472 SynthaMax Dry Media Filter - Red
202-250	722-472 SynthaMax Dry Media Filter - Black
203-250	723-472 SynthaMax Dry Media Filter - Blue

2005-06 Cadillac Escalade/ESV/EXT  
 2005-06 Chevrolet Avalanche 1500  
 2005 Chevrolet Silverado 1500  
 2005-06 Chevrolet Tahoe/Suburban 1500/2500  
 2005-06 GMC Sierra 1500/1500HD/2500HD/3500  
 2007 GMC Sierra Classic 1500/1500HD/2500HD/3500  
 2005-06 GMC Yukon/Yukon XL 1500/2500  
 4.8L V8, 5.3L V8, 6.0L V8  
 With Electric Cooling Fan & Low Profile Hood

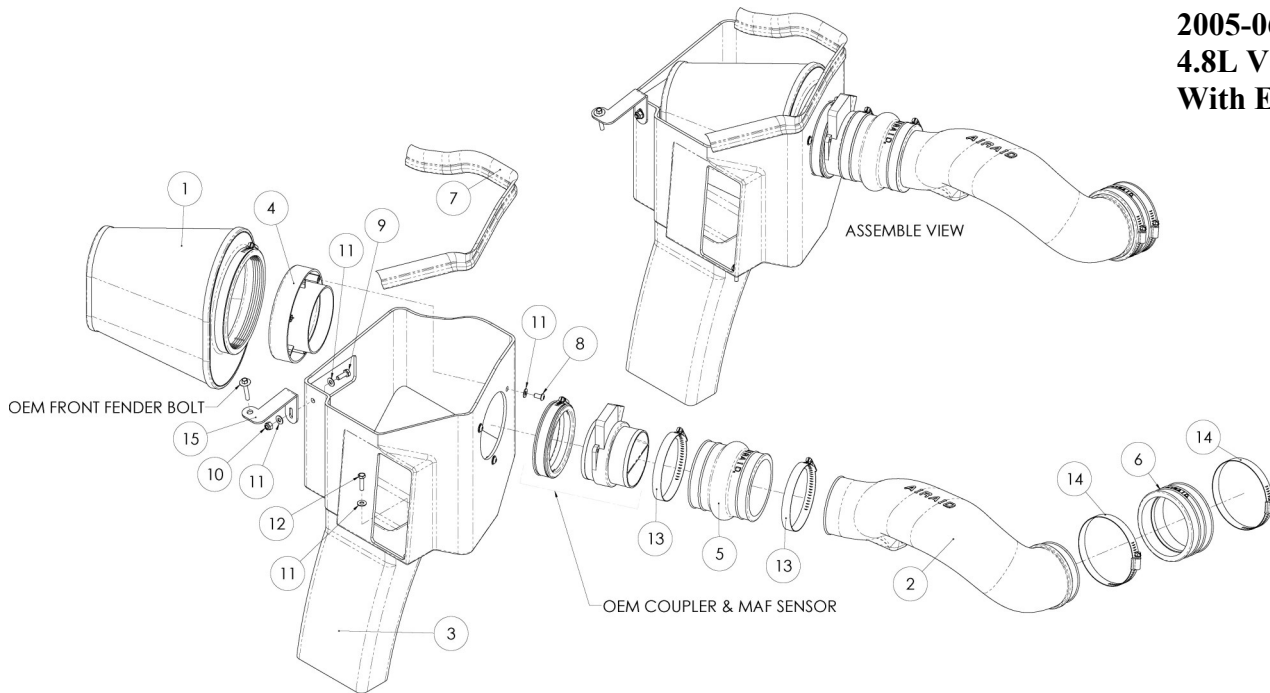

### Component Identification

1.	Airaid Premium Filter	1
2.	Airaid Intake Tube	1
3.	Cool Air Box	1
4.	Air Filter Adapter	1
5.	Urethane Hump Hose	1
6.	Urethane Coupler	1
7.	Weather Strip 25"	1
8.	1/4-20 x 1/2" Button Head Bolt	3
9.	1/4-20x 3/4" Hex Bolt	1
10.	1/4" Nylock Nut	1
11.	1/4" Flat Washer	8
12.	M6-1x25 Hex Bolt	3
13.	#60 Hose Clamp	2
14.	#64 Hose Clamp	2
15.	Bracket	1
16.	Airaid Decal	1

Full color instructions can be viewed on our web site at [Airaid.com](http://Airaid.com).

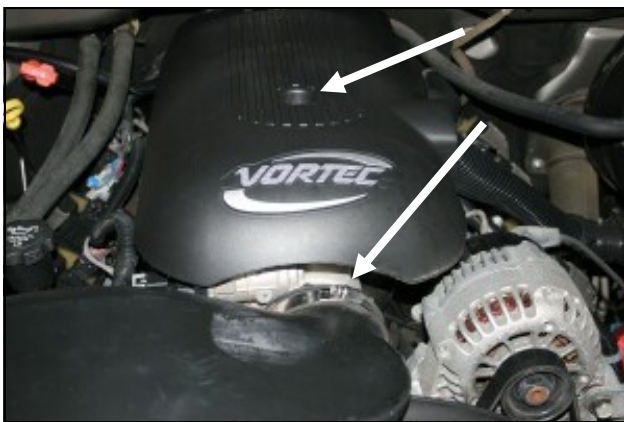

1. **Disconnect the negative battery cable.**  
 Loosen the bolt that secures the beauty cover to the engine and remove it and the cover from the vehicle. Loosen the hose clamp that secures the factory air intake tube to the throttlebody.

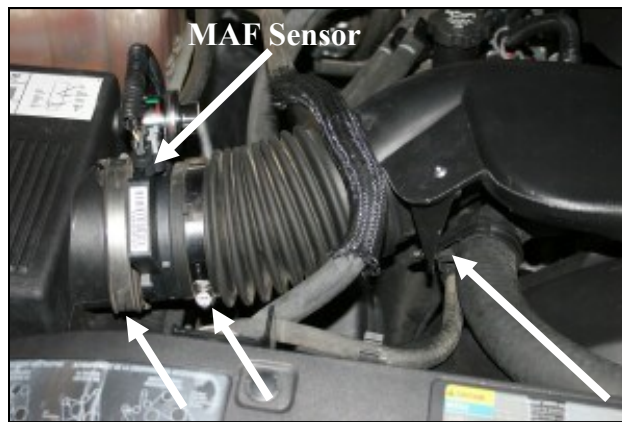

2. Loosen two hose clamps. One on each side of the Mass Air Flow (MAF) sensor. Using a flat blade screwdriver, disconnect the factory intake tube from the plastic clamp on the radiator hose by prying them apart.

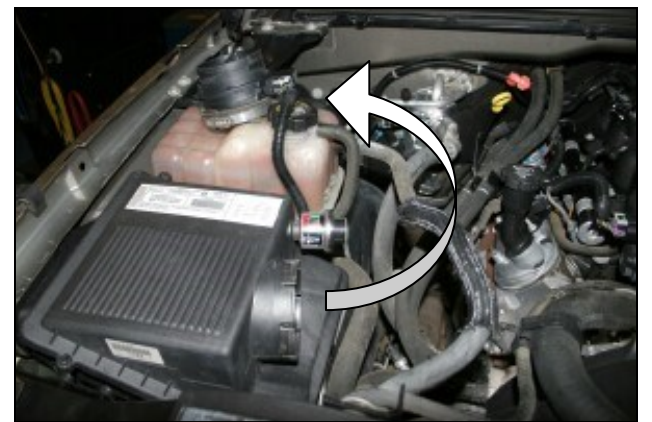

3. Remove the factory intake tube from the vehicle. Next, remove the MAF sensor and coupler from the factory airbox and set them out of the way without disconnecting the wiring harness.



4. Rock the factory air box back and forth and then lift straight up remove it from the vehicle. There are only grommets holding it in place, no bolts.

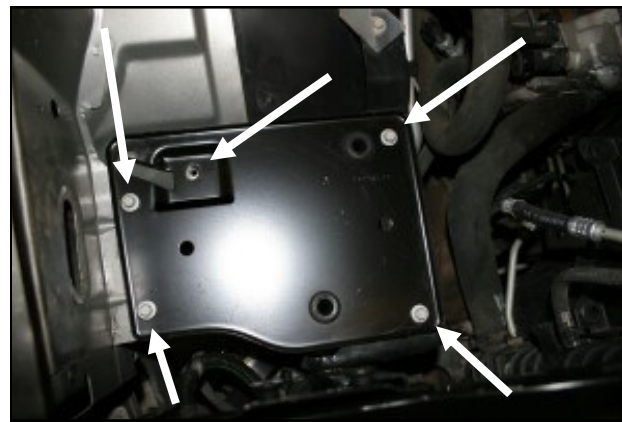

5. Using a 10mm socket, remove the bolts that secure the factory air filter housing platform and remove it from the vehicle.



6. Install the filter adapter (#4) into the Cool Air Box (#3) as shown using three 1/4" Button head bolts (#8) and three 1/4" flat washers (#11). Next, fasten the bracket (#15) to the front of the CAB as shown using one 1/4-20 hex bolt (#9) two flat washers (#10), and one 1/4" Nylock nut. Refer to the drawing above for reference.





7. Remove the factory bolt that secures the right front fender to the radiator support. It will be reused in step #8.



8. Install the CAB assembly into the vehicle where the factory airbox used to be using three 6mm hex bolts (#12) and three flat washers (#11) thru the bottom. Now reinstall the factory fender bolt thru the bracket and into the fender. Adjust the assembly for fit and tighten all bolts and nuts at this time. Apply the Airaid Foil Decal onto the Panel as shown.



9. Reinstall the MAF sensor and coupler onto the filter adapter and tighten the clamp. Next install the hump hose (#5) onto the MAF using two #60 hose clamps (#13). Leave these two clamps loose for now.



10. Install the provided coupler (#6) with two #64 hose clamps (#14) onto the throttle body. Do not tighten the clamps at this time.



11. Install the small end of the intake tube into the hump hose first and then rotate it slightly to slide the other end into coupler on the throttlebody. Adjust for fit, and then tighten all four hose clamps.



12. Install the provided weather strip (#7) along the top edge of the Airaid Cool Air Dam starting at the right fender working your way around towards the radiator. Install the Airaid Premium Filter (#1) onto the air filter adapter and tighten the hose clamp. Reinstall the factory beauty cover removed in step #1.. **Double check your work!**

Make sure there is no foreign material in the intake path. Make sure all clamps, hoses, bolts, and screws are tight. Double check the hood clearance.

**Reconnect the negative battery cable!**

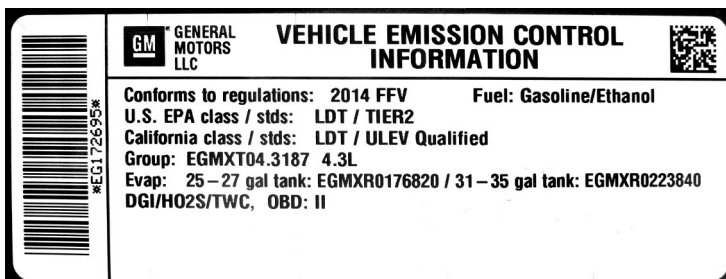

**WARNING!** If your vehicle has a Vehicle Emission Control Information decal affixed to the factory airbox, a new replacement label must be obtained and installed in a readily visible position in the engine compartment in order to remain CARB compliant. Failure to do so will prevent the vehicle from passing a smog check. Replacement labels can be ordered from your local dealership. Regulations state that the VECI label shall not be affixed to any equipment which is easily detached from the vehicle. Label placement, under the hood on a painted surface is recommended.

Thank you for purchasing the Airaid Intake System. Contact Airaid @ (800) 498-6951 8:00 AM - 5:00 PM MST weekdays for questions regarding fit or instructions that are not clear to you. Your Airaid Intake System was carefully inspected and packaged. Check that no parts are missing, or were damaged during shipping. If any parts are missing, contact Airaid. The air filter element is protected from direct exposure to water and debris; care should be taken not to drive through deep water. WATER INGESTION IS THE DRIVERS RESPONSIBILITY! The air filter is reusable and should be cleaned periodically.

### FILTER IDENTIFICATION

720-472 Airaid Oiled Media  
722-472 Synthamax Dry Media - Black

721-472 Airaid Synthamax Dry Media - Red  
723-472 Airaid Synthamax Dry Media - Blue

**For your Oiled media filter we suggest using the AIRAID Filter Tune-Up Kit!**



P/N 790-551 Aerosol Spray  
P/N 790-550 Squeeze Spray



**Synthamax**

**Do Not Oil**

Synthamax Air Filters do not require oil. Service air filter as needed by cleaning with common non-petroleum all-purpose household cleaner and water. Simple Green®, Formula 409® or equivalent works great. Apply cleaner to outside of air filter and allow to soak. Then flush filter clean from the inside out with a garden hose and repeat steps if necessary. Do not apply high pressure water or air to clean filter. Allow filter to air dry and reinstall.