



### Component Identification

1.	Airaid Premium Filter	1	9.	Silver Bracket	1
2.	Plastic "Hat"	1	10.	90° Plastic Elbow	1
3.	13" x 3.5" Tube	1	11.	1/2" x 4" Hose	1
4.	3.5" x 3.5" Coupler	1	12.	Rubber Grommet	1
5.	5.25" Gasket	1	13.	Serrated 5/16-18 Nut	1
6.	Black Speed Clamp	2	14.	M6-1 Hex Nut	1
7.	Bent Black Stud	1	15.	5/16-18 x 3/4 Hex Bolt	1
8.	Aluminum Polished Nut	1			

## Installation Instructions

### For Part Numbers:

200-104	700-420 Airaid Oiled Media Filter
201-104	701-420 SynthaMax Dry Media Filter - Red
202-104	702-420 SynthaMax Dry Media Filter - Black
203-104	703-420 SynthaMax Dry Media Filter - Blue

CHEVROLET BLAZER 1988-1994 V8 5.7L  
 CHEVROLET/GMC C1500 PICKUP 1988-1995 V6 4.3L, V8 5.0L, V8 5.7L  
 CHEVROLET/GMC C1500 SUBURBAN 1992-1995 V8 5.7L  
 CHEVROLET/GMC C2500 PICKUP 1988-1995 V6 4.3L, V8 5.0L, V8 5.7L  
 CHEVROLET/GMC C2500 SUBURBAN 1992-1995 V8 5.7L  
 CHEVROLET/GMC C3500 PICKUP 1988-1995 V8 5.7L  
 CHEVROLET/GMC K1500 PICKUP 1988-1995 V6 4.3L, V8 5.0L, V8 5.7L  
 CHEVROLET/GMC K1500 SUBURBAN 1992-1995 V8 5.7L  
 CHEVROLET/GMC K2500 PICKUP 1988-1995 V6 4.3L, V8 5.0L, V8 5.7L  
 CHEVROLET/GMC K2500 SUBURBAN 1992-1995 V8 5.7L  
 CHEVROLET/GMC K3500 PICKUP 1988-1995 V8 5.7L  
 CHEVROLET R10 SUBURBAN 1988-1988 V8 5.7L  
 CHEVROLET/GMC R1500 SUBURBAN 1989-1991 V8 5.7L  
 CHEVROLET R20 PICKUP 1988-1988 V8 5.7L  
 CHEVROLET R20 SUBURBAN 1988-1988 V8 5.7L  
 CHEVROLET/GMC R2500 SUBURBAN 1989-1991 V8 5.7L  
 CHEVROLET R30 PICKUP 1988-1988 V8 5.7L  
 CHEVROLET R3500 PICKUP 1989-1991 V8 5.7L  
 CHEVROLET TAHOE 1995-1995 V8 5.7L  
 CHEVROLET V10 SUBURBAN 1988-1988 V8 5.7L  
 CHEVROLET V1500 SUBURBAN 1989-1991 V8 5.7L  
 CHEVROLET V20 SUBURBAN 1988-1988 V8 5.7L  
 CHEVROLET/GMC V2500 SUBURBAN 1989-1991 V8 5.7L  
 CHEVROLET V30 PICKUP 1988-1988 V8 5.7L  
 CHEVROLET V3500 PICKUP 1989-1991 V8 5.7L  
 GMC JIMMY 1988-1991 V8  
 GMC R2500 PICKUP 1988-1989 V8 5.7L-  
 GMC R2500 SUBURBAN 1988-1991 V8 5.7L  
 GMC R3500 PICKUP 1988-1991 V8 5.7L-  
 GMC V1500 SUBURBAN 1988-1991 V8 5.7L  
 GMC V2500 SUBURBAN 1988-1991 V8 5.7L  
 GMC V3500 PICKUP 1988-1991 V8 5.7L-  
 GMC YUKON 1992-1995 V8 5.7L

Full color instructions can be viewed on our web site at [Airaid.com](http://Airaid.com). Use the **Product Search** function to find your part number, and click **View Details**.

## I DISCONNECT NEGATIVE (-) BATTERY CABLE

## II Remove Factory Intake Assembly

- Loosen the wing on the top of the factory air intake assembly and remove assembly from vehicle.
- Remove and discard the 1" crankcase breather ring. See Fig#1 (save valve cover breather tube for later use)
- Use a 13mm socket and wrench to remove the strap that secures the silencer tube on the passenger side fender housing. See Fig#2
- Remove entire factory air cleaner assembly from vehicle.

## III 1987-1992 : Install the AIRAID Throttle Body Stud and Airaid Hat

- Replace the "S" shaped threaded stud into the top of the throttle body. (Note: also screw the 6mm serrated nut onto the stud.) See Fig#3

## IV 1993-1995: Install the AIRAID Throttle Body Stud and Airaid Hat

- Remove the two air cleaner hold down studs with a 5/16" wrench. See Fig# 4. Take care not to loosen throttle body.
- Screw the "S" shaped 1/4"x20 threaded stud into the top of the throttle body. (Note: The factory threaded hole is 1/4"x20 thread, located in front of the injectors and between the throttle bores.) See Fig#3
- Also screw the 6mm serrated nut onto the stud. See Fig#3

## V Mount the AIRAID Intake System Brace

- Locate the dipstick tube mounting bracket on the passenger side cylinder head. Using a 3/8" socket, remove the bolt and save for later use.
- Carefully pull the dipstick away from the cylinder head and position the silver Airaid mounting bracket between the cylinder head and the dipstick bracket. See Fig#5
- Reinstall bolt and tighten loosely so that adjustments may be made later.

## VI Assemble and Install the AIRAID Intake System (Refer to Fig#6 & Fig#7)

- Check for and remove any foreign debris in the intake tube and filter.
- Insert rubber grommet into the hole in the rear of the Airaid hat.
- Insert the black plastic elbow into the grommet hole in the rear of the Airaid hat.
- Place the supplied gasket around the top perimeter of the throttle body.
- Position the Airaid hat over the throttle body and guide over the Airaid stud.
- Tighten the Airaid hat loosely with the billet nut provided.
- Insert 1/2" x 4" hose over plastic elbow and connect to valve cover breather tube, secure using the two black clamps provided.
- Slide the stainless steel clamp with rubber insert over the opening of the Airaid hat.
- Insert the silver Airaid tube into the stainless steel coupler, connecting the tube to the hat.
- Align the tab on the tube with the end of the bracket attached to the dipstick bracket and fasten with the hardware provided.

## VI Finishing Up

- Tighten all clamps, brackets, nuts & bolts.
- Inspect overall work and check hood clearance.
- Re-connect negative battery cable.

FIG#1



FIG#2



FIG#3

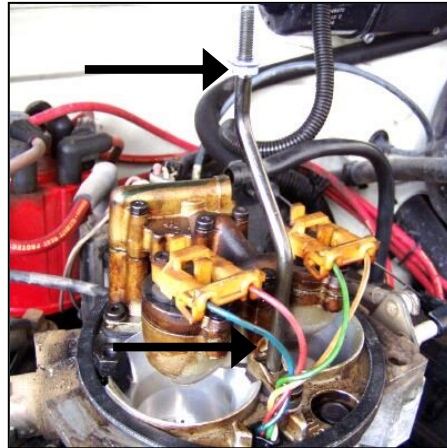

FIG#4



FIG#5

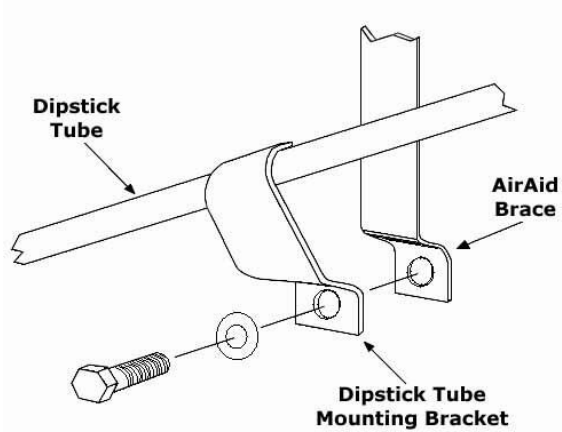

FIG#6

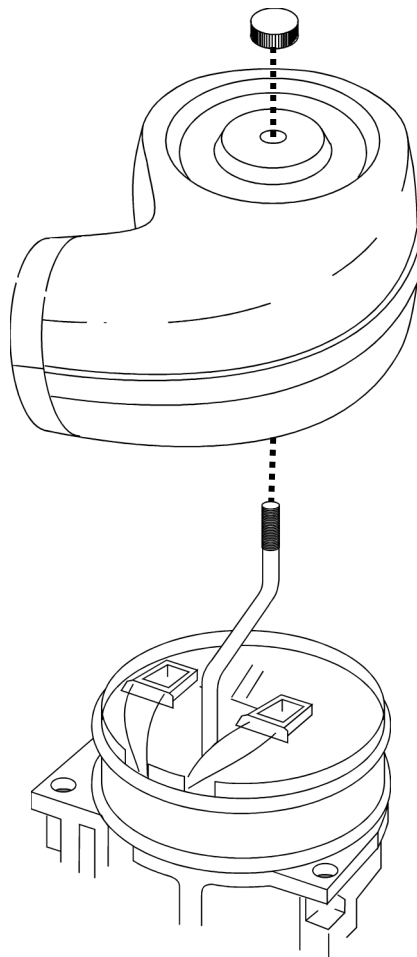

FIG#7



Place the Airaid Decal onto the Tube as shown.

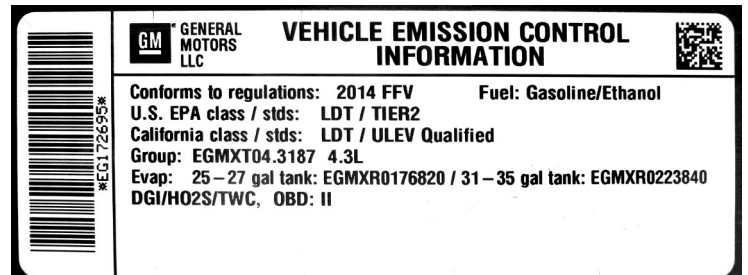

**WARNING!** If your vehicle has a Vehicle Emission Control Information decal affixed to the factory airbox, a new replacement label must be obtained and installed in a readily visible position in the engine compartment in order to remain CARB compliant. Failure to do so will prevent the vehicle from passing a smog check. Replacement labels can be ordered from your local dealership. Regulations state that the VECI label shall not be affixed to any equipment which is easily detached from the vehicle. Label placement, under the hood on a painted surface is recommended.

Thank you for purchasing the Airaid Intake System. Contact Airaid @ (800) 498-6951 8:00 AM - 5:00 PM MST weekdays for questions regarding fit or instructions that are not clear to you. Your Airaid Intake System was carefully inspected and packaged. Check that no parts are missing, or were damaged during shipping. If any parts are missing, contact Airaid. The air filter element is protected from direct exposure to water and debris; care should be taken not to drive through deep water. WATER INGESTION IS THE DRIVERS RESPONSIBILITY! The air filter is reusable and should be cleaned periodically.

**FILTER IDENTIFICATION**

700-420 Airaid Oiled Media  
702-420 Airaid SynthaMax Dry Media - Black

701-420 Airaid SynthaMax Dry Media - Red  
703-420 Airaid SynthaMax Dry Media - Blue

**For your Oiled media filter we suggest using the AIRAID Filter Tune-Up Kit!**



**Do Not Oil**



Synthamax Air Filters do not require oil. Service air filter as needed by cleaning with common non-petroleum all-purpose household cleaner and water. Simple Green®, Formula 409® or equivalent works great. Apply cleaner to outside of air filter and allow to soak. Then flush filter clean from the inside out with a garden hose and repeat steps if necessary. Do not apply high pressure water or air to clean filter. Allow filter to air dry and reinstall.

P/N 790-551 Aerosol Spray  
P/N 790-550 Squeeze Spray