



INSTALLATION INSTRUCTIONS



2016 FIAT 500X 2.4L

PART NO. 19279

BILL OF MATERIALS:

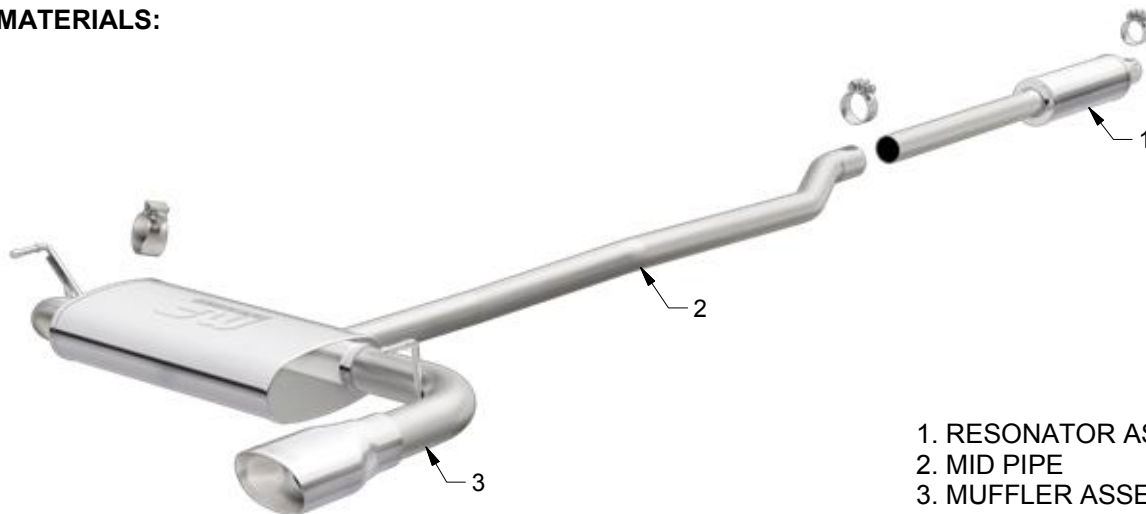

- 1. RESONATOR ASSEMBLY
- 2. MID PIPE
- 3. MUFFLER ASSEMBLY



WEAR SAFETY GLASSES



READ INSTRUCTIONS THOROUGHLY BEFORE INSTALLING PRODUCT

SHOP SUPPLIES:



SPRAY LUBRICANT

To ease removal of existing exhaust components (especially on older vehicles) spray penetrating lubricant on all fasteners and hangers/insulators that will be loosened or removed and let soak before disassembly.

HARDWARE KIT:

- 1. [1] 2.18" Torca Clamp
- 2. [2] 2.25" Torca Clamp

MINIMUM REQUIRED TOOLS:



15mm
13mm



Hanger Tool
(Or Pry Bar)

MAGNAFLOW RECOMMENDS PROFESSIONAL INSTALLATION ON ALL THEIR PRODUCTS



WARNING: When working on, under, or around any vehicle exercise caution. Please allow the vehicle's exhaust system to cool before removal, as exhaust system temperatures may cause severe burns. If working without a lift always consult vehicle manual for correct lifting specifications. Always wear safety glasses and ensure a safe work area. Serious injury or death could occur if safety measures are not followed.

ATTENTION: Always install any supplied band or U-bolt clamps to the proper torque specifications of 40-45 ft-lbs for band clamps and 30-35 ft-lbs for U-bolt clamps. Over tightening will result in the clamp breaking and will NOT be warranted by MagnaFlow.

INSTALLATION INSTRUCTIONS



Step 1. To remove the OEM exhaust loosen the factory clamps in front of the resonator assembly and the one attaching the resonator assembly to the mid pipe. Disengage all welded hangers from the rubber insulators. Be sure to retain all mounting hardware as it will be needed to install your new MAGNAFLOW system. The OEM system may now be removed.



Step 2. Install the Resonator Assembly by slipping the inlet end over the outlet of the catalytic converter. Loosely secure using the supplied 2.18" clamp.



Step 3. Next loosely attach the Mid Pipe to the Resonator Assembly outlet using the supplied clamp.

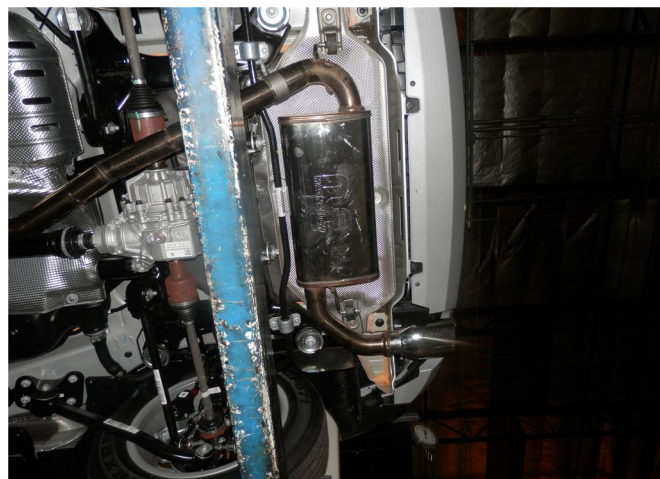

Step 4. Loosely install the Muffler Assembly to the Mid Pipe with the supplied clamp. Locate both welded hangers to the OEM rubber insulators.



Step 5. Once a final position has been chosen for the new exhaust system, evenly tighten all clamps from front to rear using the torque specifications on page one of the instructions. Inspect all fasteners after 25-50 miles of operation and re-tighten if necessary.